

**Model 269  
Photomultiplier Base  
Operating and Service Manual**

This manual applies to instruments marked  
"Rev 34" on rear panel

# **Advanced Measurement Technology, Inc.**

a/k/a/ ORTEC<sup>®</sup>, a subsidiary of AMETEK<sup>®</sup>, Inc.

## **WARRANTY**

ORTEC\* warrants that the items will be delivered free from defects in material or workmanship. ORTEC makes no other warranties, express or implied, and specifically NO WARRANTY OF MERCHANTABILITY OR FITNESS FOR A PARTICULAR PURPOSE.

ORTEC's exclusive liability is limited to repairing or replacing at ORTEC's option, items found by ORTEC to be defective in workmanship or materials within one year from the date of delivery. ORTEC's liability on any claim of any kind, including negligence, loss, or damages arising out of, connected with, or from the performance or breach thereof, or from the manufacture, sale, delivery, resale, repair, or use of any item or services covered by this agreement or purchase order, shall in no case exceed the price allocable to the item or service furnished or any part thereof that gives rise to the claim. In the event ORTEC fails to manufacture or deliver items called for in this agreement or purchase order, ORTEC's exclusive liability and buyer's exclusive remedy shall be release of the buyer from the obligation to pay the purchase price. In no event shall ORTEC be liable for special or consequential damages.

### **Quality Control**

Before being approved for shipment, each ORTEC instrument must pass a stringent set of quality control tests designed to expose any flaws in materials or workmanship. Permanent records of these tests are maintained for use in warranty repair and as a source of statistical information for design improvements.

### **Repair Service**

If it becomes necessary to return this instrument for repair, it is essential that Customer Services be contacted in advance of its return so that a Return Authorization Number can be assigned to the unit. Also, ORTEC must be informed, either in writing, by telephone [(865) 482-4411] or by facsimile transmission [(865) 483-2133], of the nature of the fault of the instrument being returned and of the model, serial, and revision ("Rev" on rear panel) numbers. Failure to do so may cause unnecessary delays in getting the unit repaired. The ORTEC standard procedure requires that instruments returned for repair pass the same quality control tests that are used for new-production instruments. Instruments that are returned should be packed so that they will withstand normal transit handling and must be shipped PREPAID via Air Parcel Post or United Parcel Service to the designated ORTEC repair center. The address label and the package should include the Return Authorization Number assigned. Instruments being returned that are damaged in transit due to inadequate packing will be repaired at the sender's expense, and it will be the sender's responsibility to make claim with the shipper. Instruments not in warranty should follow the same procedure and ORTEC will provide a quotation.

### **Damage in Transit**

Shipments should be examined immediately upon receipt for evidence of external or concealed damage. The carrier making delivery should be notified immediately of any such damage, since the carrier is normally liable for damage in shipment. Packing materials, waybills, and other such documentation should be preserved in order to establish claims. After such notification to the carrier, please notify ORTEC of the circumstances so that assistance can be provided in making damage claims and in providing replacement equipment, if necessary.

---

Copyright © 2002, Advanced Measurement Technology, Inc. All rights reserved.

\*ORTEC<sup>®</sup> is a registered trademark of Advanced Measurement Technology, Inc. All other trademarks used herein are the property of their respective owners.

## CONTENTS

WARRANTY .....	ii
SAFETY INSTRUCTIONS AND SYMBOLS .....	iv
SAFETY WARNINGS AND CLEANING INSTRUCTIONS .....	v
1. DESCRIPTION .....	1
2. SPECIFICATIONS* .....	1
2.1. BASE .....	1
2.2. SIGNALS .....	1
2.3. CONNECTORS .....	1
2.4. RELATED EQUIPMENT .....	2
2.5. WEIGHTS AND DIMENSIONS .....	2
3. INSTALLATION .....	2
3.1. DETECTOR MOUNTING .....	2
3.2. PHOTOMULTIPLIER INSERTION .....	2
3.3. INITIAL ADJUSTMENTS .....	2
3.4. CONNECTION INTO A SYSTEM .....	3
4. OPERATION .....	3
4.1. TIMING WITH PHOTOMULTIPLIERS .....	3
4.2. APPLICATIONS .....	4
4.2.1. Typical Fast-Slow Coincidence System Using Plastic Scintillators .....	6
4.2.2. Typical Fast-Slow Coincidence Using NaI(Tl) .....	9
4.2.3. Fast Coincidence Using Ge(Li-Drifted) Detectors .....	9
5. MAINTENANCE .....	9

## SAFETY INSTRUCTIONS AND SYMBOLS

This manual contains up to three levels of safety instructions that must be observed in order to avoid personal injury and/or damage to equipment or other property. These are:

**DANGER** Indicates a hazard that could result in death or serious bodily harm if the safety instruction is not observed.

**WARNING** Indicates a hazard that could result in bodily harm if the safety instruction is not observed.

**CAUTION** Indicates a hazard that could result in property damage if the safety instruction is not observed.

Please read all safety instructions carefully and make sure you understand them fully before attempting to use this product.

In addition, the following symbol may appear on the product:



**ATTENTION – Refer to Manual**



**DANGER – High Voltage**

Please read all safety instructions carefully and make sure you understand them fully before attempting to use this product.

## SAFETY WARNINGS AND CLEANING INSTRUCTIONS

**DANGER** Opening the cover of this instrument is likely to expose dangerous voltages. Disconnect the instrument from all voltage sources while it is being opened.

**WARNING** Using this instrument in a manner not specified by the manufacturer may impair the protection provided by the instrument.

### Cleaning Instructions

To clean the instrument exterior:

- Unplug the instrument from the ac power supply.
- Remove loose dust on the outside of the instrument with a lint-free cloth.
- Remove remaining dirt with a lint-free cloth dampened in a general-purpose detergent and water solution. Do not use abrasive cleaners.

**CAUTION** To prevent moisture inside of the instrument during external cleaning, use only enough liquid to dampen the cloth or applicator.

- Allow the instrument to dry completely before reconnecting it to the power source.

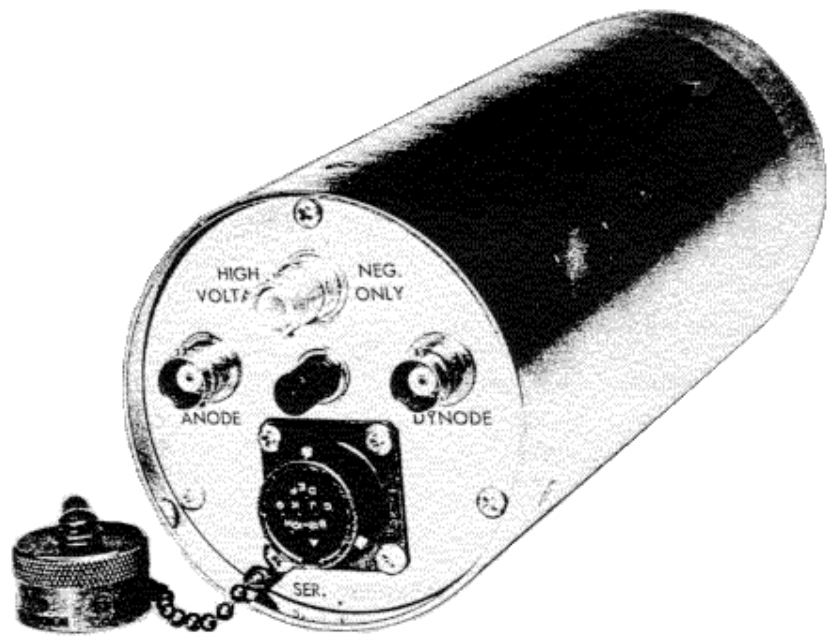

# ORTEC 269 PHOTOMULTIPLIER BASE

## 1. DESCRIPTION

The ORTEC 269 Photomultiplier Base structure provides a mechanical assembly and resistive voltage divider network, with appropriate capacity decoupling, for operation of the Amperex 56 AVP-UVP, etc., and the 58 AVP-UVP/XP-1040 types of photomultipliers and RCA tubes of the 6810 Series. These tubes are specifically designed for high-pulse current timing applications, and therefore this base

structure complements them by maintaining good pulse fidelity over a wide range of signal currents (see Fig. 1.1). The unit provides two outputs: the negative anode signal for timing applications and a linear signal from the tenth dynode. The linear signal is of special importance in any experiment in which energy measurements are desired.

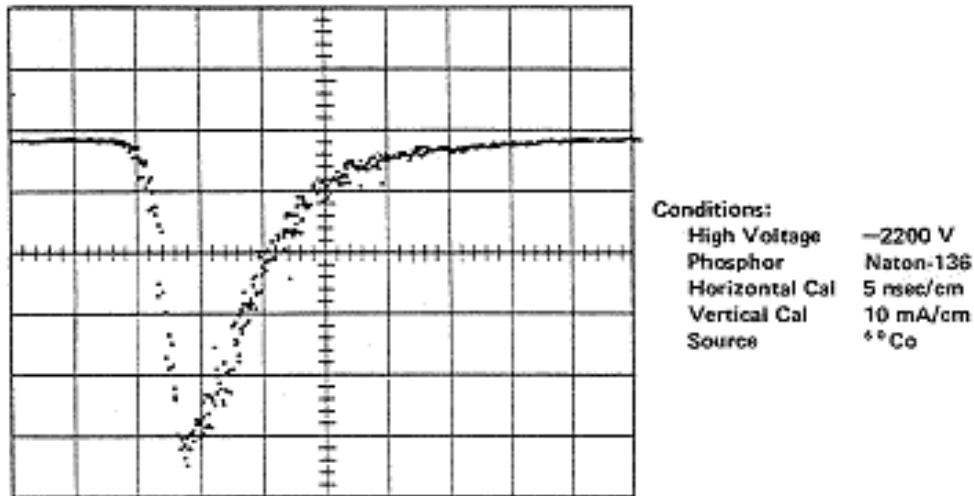

Fig. 1.1. Anode Output Pulse.

## 2. SPECIFICATIONS

### 2.1. BASE

**High Voltage** Negative, 3 kV max.

**Bleeder Current** 2 mA max (last 4 dynodes available for optional voltage stabilization).

### 2.2. SIGNALS

**Anode** Negative timing signal, 50 $\Omega$  dc-coupled, back-terminated; very good pulse quality for signal currents to 0.5 for Amperex tubes.

**Dynode** Positive linear signal from 10<sup>th</sup> dynode; capacity coupled; impedance, -1 M $\Omega$ .

**Internal Controls** Voltage adjustment for focus and deflection electrodes and for 14<sup>th</sup> dynode.

### 2.3. CONNECTORS

**Anode** BNC.

**Dynode** BNC.

**High Voltage** SHV - AMP type 51494-2.

**Auxiliary** MS3112E12-10s or Bendix PT02E-12-10S.

**PMT Socket** A 20-pin Jeduc B20-102 type.

## 2.4. RELATED EQUIPMENT

The Anode timing signal can be furnished to an ORTEC Fast Discriminator when using either a NaI(Tl) or plastic scintillator. For plastic scintillators only, the Anode signal can be fed directly to the Start or Stop input of an ORTEC Time to Pulse Height Converter for time spectroscopy.

The linear output from the 10th dynode is normally processed through an ORTEC Scintillation Preamplifier and a Shaping Amplifier for energy spectroscopy.

An ORTEC 216 Magnetic Shield for 2-in.-diam. PM tubes or a 217 for 5-in.-diam. tubes is recommended for reduction of interference from magnetic fields.

High voltage, at the level recommended by the manufacturer of the PM tube, can be furnished from an ORTEC High Voltage Power Supply. The complete cable, ORTEC C36-12, is available for this connection.

## 2.5. WEIGHTS AND DIMENSIONS

See Table 2.1 below.

Table 2.1

Unit	Net Weight (lb)	Shipping Weight (lb)	Dimensions
ORTEC 269 PM Base	1.4 (0.63 kg)	3 (1.37 kg)	3-in. dia, 3 in. long
ORTEC 216 Shield	1 (0.45 kg)	2 (0.9 kg)	3-in. dia; assembled 269 and 216, 15 in. long
ORTEC 217 Shield	2.75 (1.25 kg)	5 (2.25 kg)	6-in. dia; assembled 269 and 217, 19 in. long
ORTEC C36-12 Cable	<1 (0.45 kg)	<1 (0.45 kg)	12 ft
ORTEC 269-C1*	<1 (0.45 kg)	<1 (0.45 kg)	3-in. dia, 2 in. long

\*A modified RCA-AJ2143 adapter that is a necessary accessory when using the RCA-4522 with the ORTEC 269. Both the RCA-AJ2143 and the RCA 4522 are no longer in production.

## 3. INSTALLATION

### 3.1. DETECTOR MOUNTING

In order to obtain the ultimate in pulse fidelity, the anode of the 269 is connected to ground potential; that is, the photocathode must be at negative high voltage. The 269 assures that this high voltage is not dropped across the glass envelope of the photomultiplier by providing a shield voltage on the conductive external surface of the photomultiplier. Care should be taken to prevent the scintillator from imposing a ground at the front surface of the photocathode. A drawing of the suggested method of mounting a simple detector is shown in Figure 3.1.

Note: When used with the RCA-6810A, the shorting jumper between pins 9 and 7 should be removed and placed between pins 9 and 8.

### 3.2. PHOTOMULTIPLIER INSERTION

The magnetic shield, if used, should be removed. The tube may now be directly inserted into the socket. Place the felt washers around the photomultiplier and remount the magnetic shield.

### 3.3. INITIAL ADJUSTMENTS

The high-voltage divider cover should be removed.

**WARNING** The voltages used in this network are dangerous. Use caution when adjusting the controls.

The controls of the unit are trimmed for optimum operation with a specific PM at the factory.



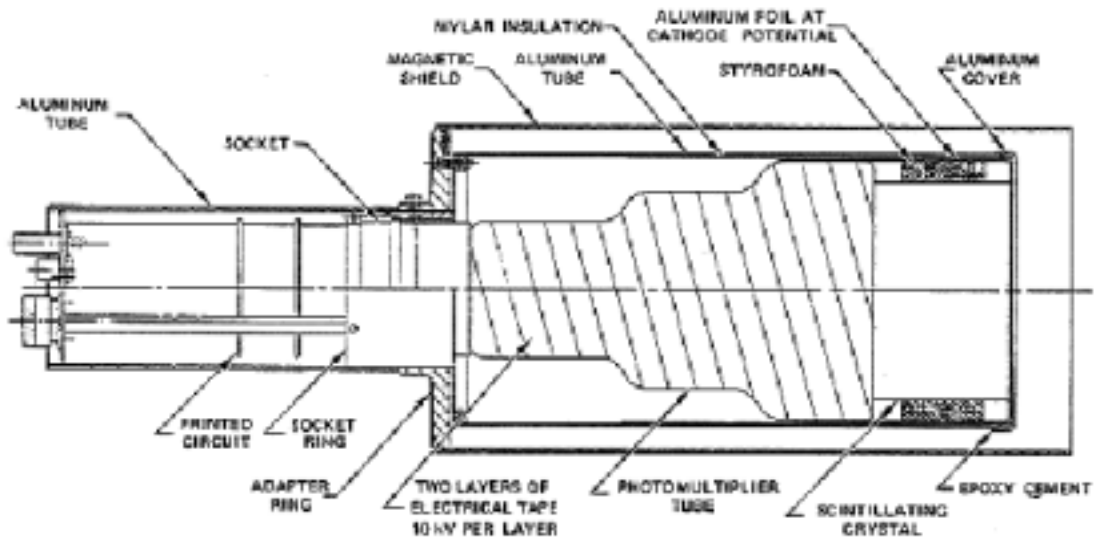

Fig. 3.1. Cutaway Drawing of PM-Scintillator Mounting.

However, the unit will probably need trimming again if a different PM is used. The following adjustments need to be performed rarely more than once with a specific PM unless the operating HV is varied more than 200 V:

1. Observe the anode output on a fast rise time oscilloscope (if coaxial cables are used, they should be terminated).
2. Apply negative 2200 V (or the voltage at which the tube is to be operated) to the high-voltage connector.
3. Place a radiation source, appropriate to the chosen scintillator, near the detector.
4. Observe the output waveform and adjust the three controls for optimum gain and pulse

shape. (The deflector adjustment will have no effect when RCA photomultipliers are used.)

5. Turn off the high voltage and replace the HV divider cover. The unit is now ready for operation.

### 3.4. CONNECTION INTO A SYSTEM

The dynode signal should be coupled via a scintillation preamplifier such as the ORTEC 113 to a shaping amplifier if linear energy information is desired. The anode signal should then be coupled via 50- $\Omega$  coaxial cable to the instrument desired (care should be taken to assure that the coaxial cable is terminated).

## 4. OPERATION

Once the steps outlined in Section 3 of this manual are performed, the unit is ready for use. High voltage may be applied and adjusted for the appropriate gain associated with the specific experiment. The gain will vary by approximately a factor of 2 with voltage change of 100 V.

### 4.1. TIMING WITH PHOTOMULTIPLIERS

Timing with photomultipliers implies some type of coincidence measurement. This measurement may

be performed with standard coincidence circuits such as the pulse overlap type, which are essentially signal-channel time analyzers; or with time-to-pulse height converters, which are differential, or multi-channel, time analyzers.

The response of the coincidence system to a prompt cascade always has finite width which comes from a variety of sources. The most important of these are as follows:

1. Variation of time of interaction of radiation with the scintillator and the amount of energy deposited therein
2. Finite decay time of light-emitting states in the phosphor and variation of times of photon arrival at the multiplier cathode
3. Variation of transit time of photoelectrons in the photomultiplier due to different path lengths and to variation of initial energy and angle of the secondary electrons
4. Jitter and uncertainties of times of triggering of the associated electronics

The variation in the time of interaction can be minimized by appropriate geometry and small scintillators at a corresponding loss in efficiency and average energy deposition.

For a complete discussion of timing with photomultipliers, the reader is referred to some of the excellent literature available on the subject.<sup>1-3</sup>

## 4.2. APPLICATIONS

The different applications for the 269 are essentially limitless, but since the unit was designed primarily for timing applications, block diagrams for two specific systems for this type of application are given (Figs 4.1 and 4.4). Typical resolution curves are also given (Figs. 4.2, 4.3, and 4.5) from which operational characteristics of other systems may be implied. Figures 4.6–4.10 are block diagrams of typical timing systems.

<sup>1</sup>A. Schwarzchild, *Nucl. Inst. Methods* 21, 1 (1963).

<sup>2</sup>G. Present et al., *Nucl. Instruments Methods* 31, 71 (1964).

<sup>3</sup>E. Gatti and V. Svelto, *Nucl. Inst. Methods* 30, 213 (1964).

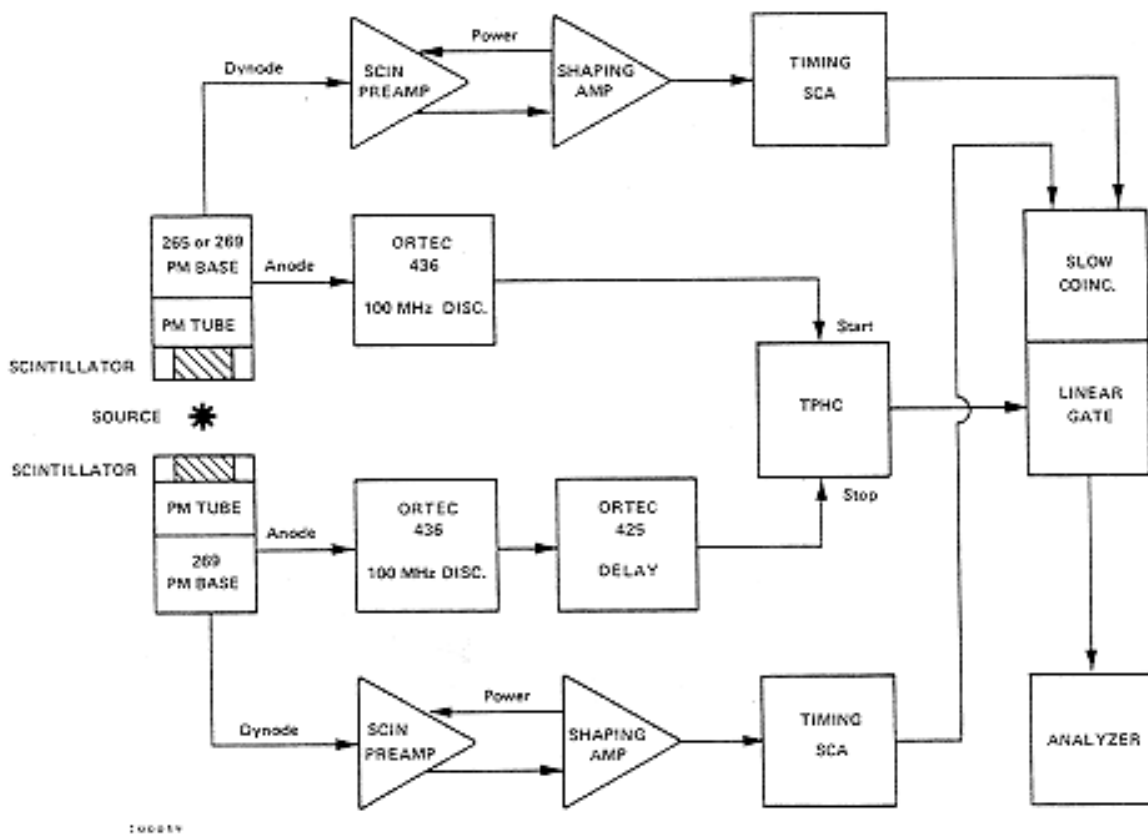

Fig. 4.1. Simple Fast-Slow Timing System.

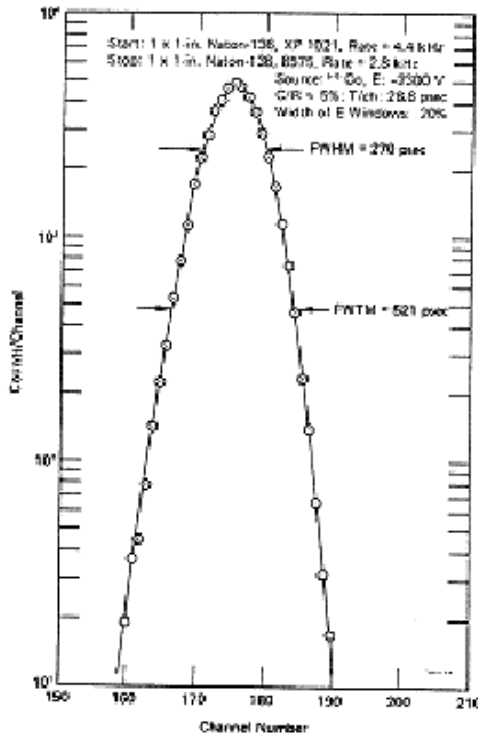

Fig. 4.2. Typical Coincidence Spectrum Using Plastic Scintillators.

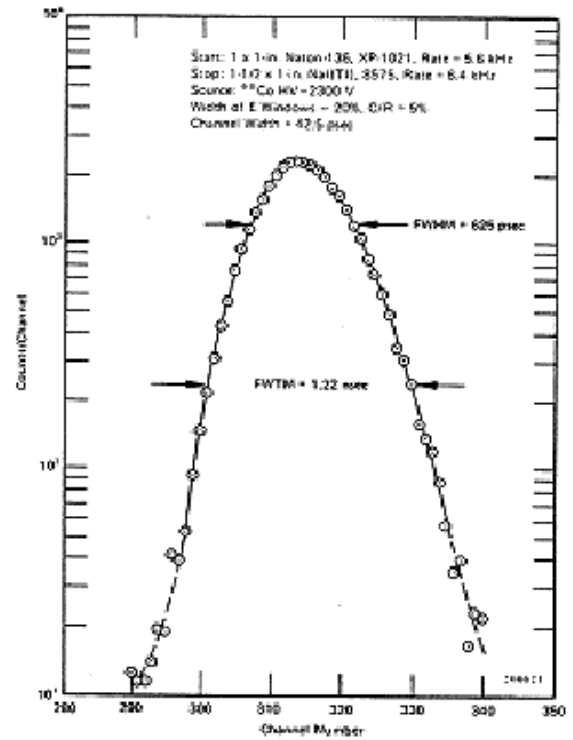

Fig. 4.3. Typical Coincidence Spectrum Using NaI(Tl) Scintillator.

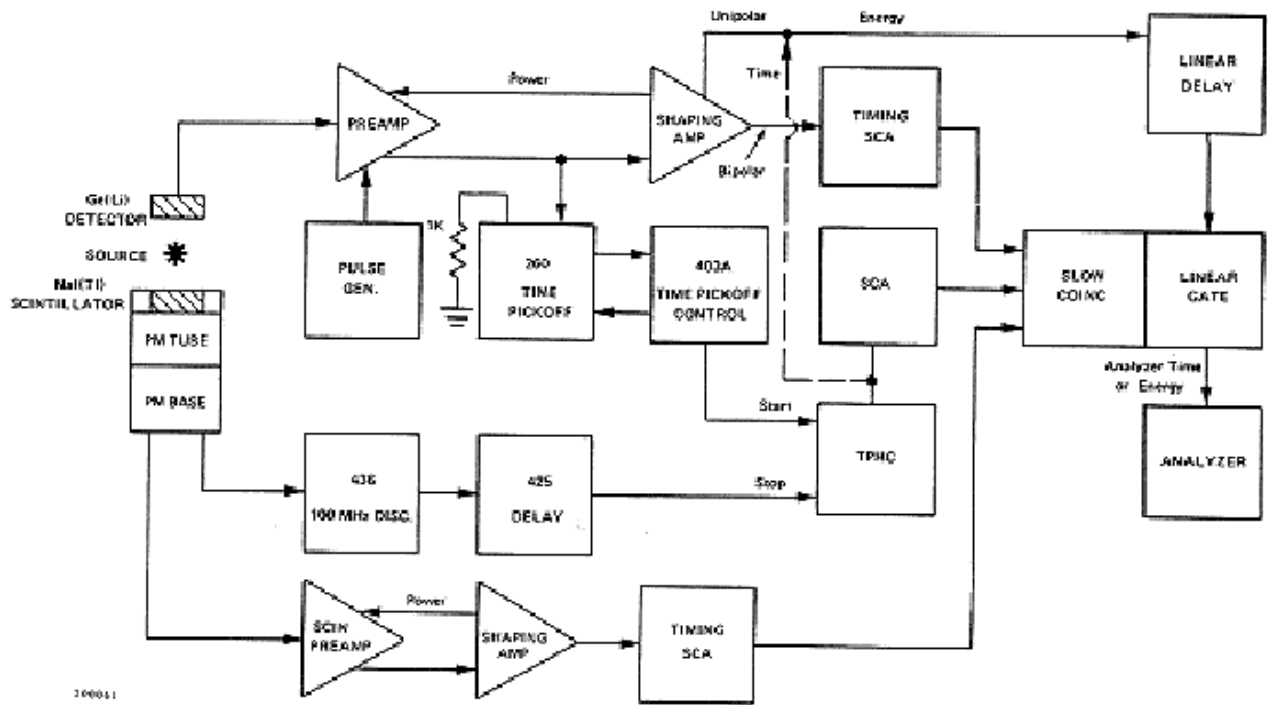

Fig. 4.4. Gamma-Gamma Coincidence System with a Ge(Li-Drifted) Detector.

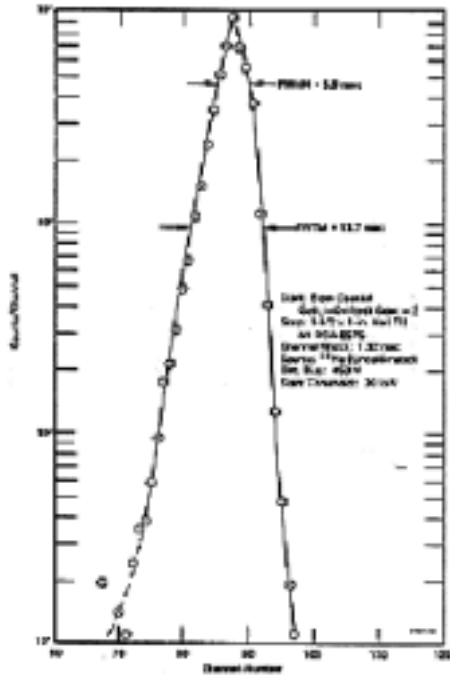

Fig. 4.5. Timing Spectrum with Ge(Li-Drifted) Detector.

#### 4.2.1. Typical Fast-Slow Coincidence System Using Plastic Scintillators

Figure 4.1 is a block diagram of a system that might be used to perform lifetime measurements or to study the time dispersion associated with some prescribed coincidence events. It does not represent an optimum system if clean slopes of the coincidence curves are required to four or five decades, but will give clean spectra to at least three decades at moderately high count rates.

The time spectrum shown in Fig. 4.2 represents what may easily be obtained under laboratory conditions using the 269 and other appropriate equipment. It is important to remember that the resolution obtainable varies as  $1/\sqrt{n}$ , where  $n$  represents the number of photoelectrons created by the event, and is therefore representative of the amount of energy deposited in the scintillation phosphor and is strongly influenced by PM optics.

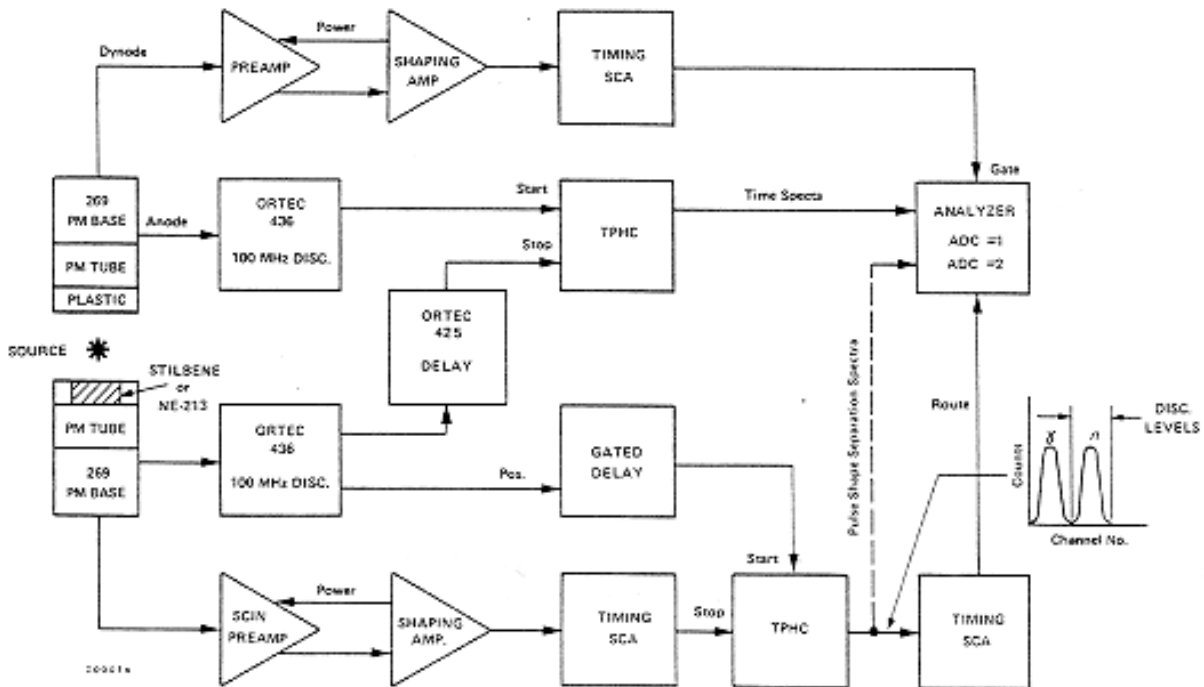

Fig. 4.6. Fast-Fast Coincidence (Photomultiplier Tube) with Pulse Shape Discrimination.

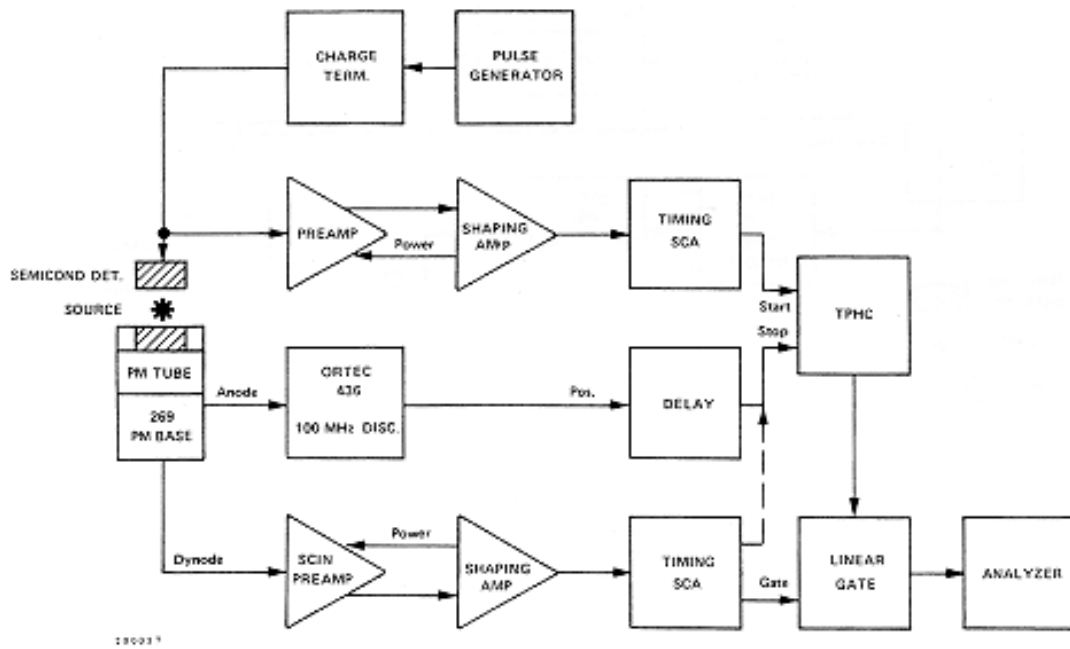

Fig. 4.7. Fast Timing System (Semiconductor Detector-Photomultiplier Tube) for Coincidence Using Crossover Pickoff Techniques.

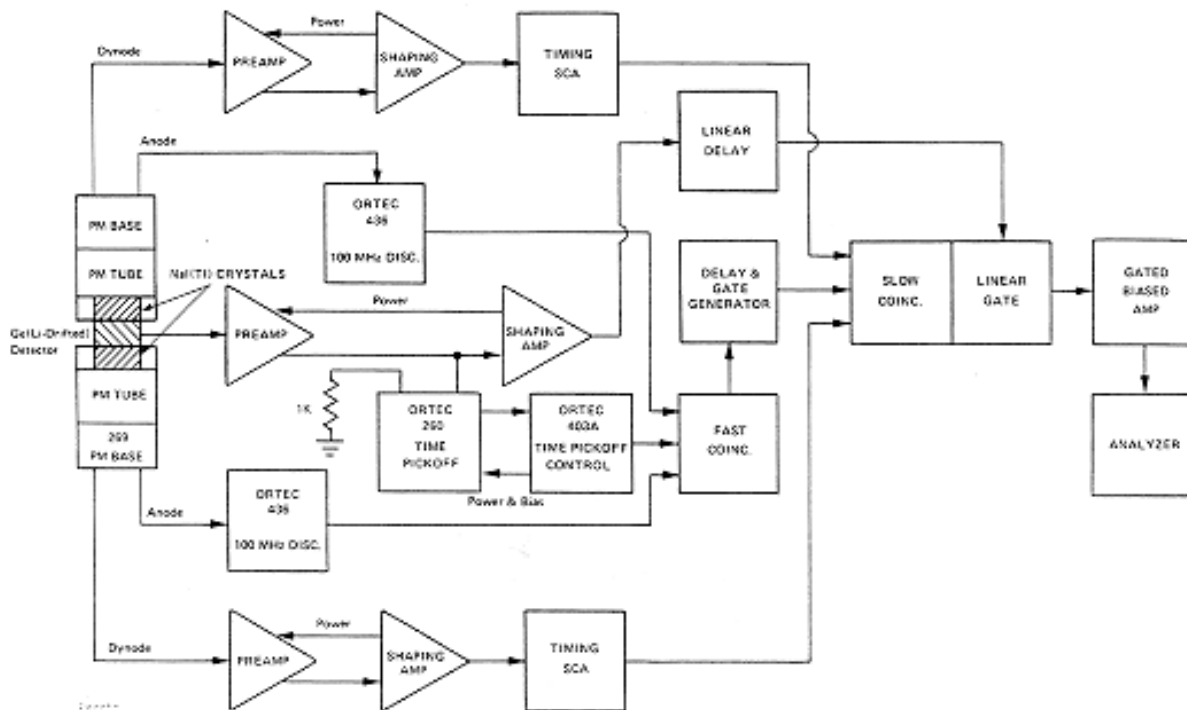

Fig. 4.8. Gamma-Ray Pair Spectrometer.

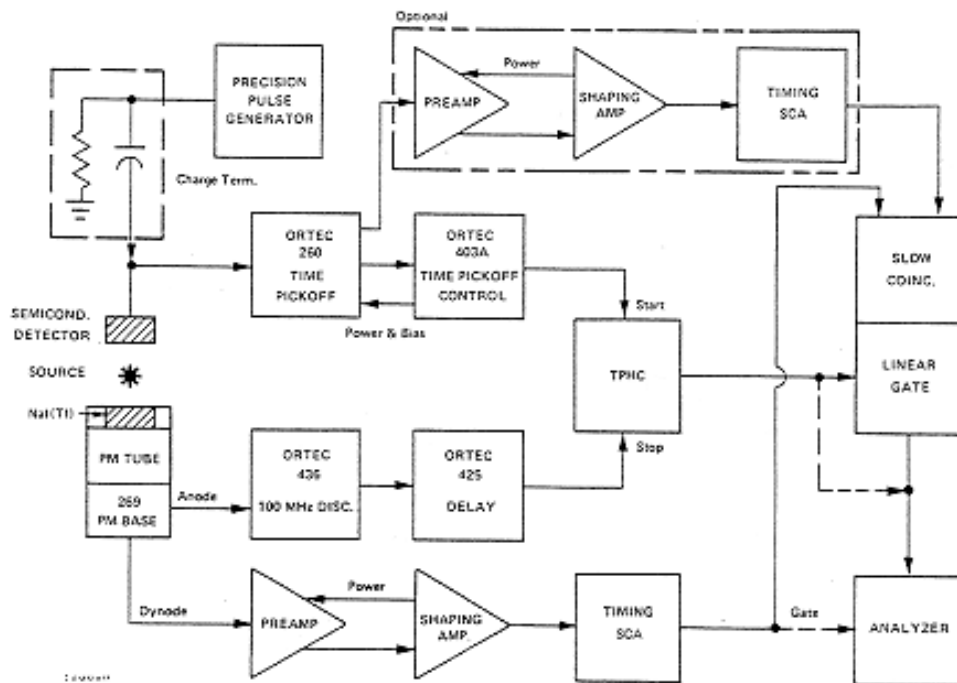

Fig. 4.9. Subnanosecond Timing System (Semiconductor-Photomultiplier Tube).

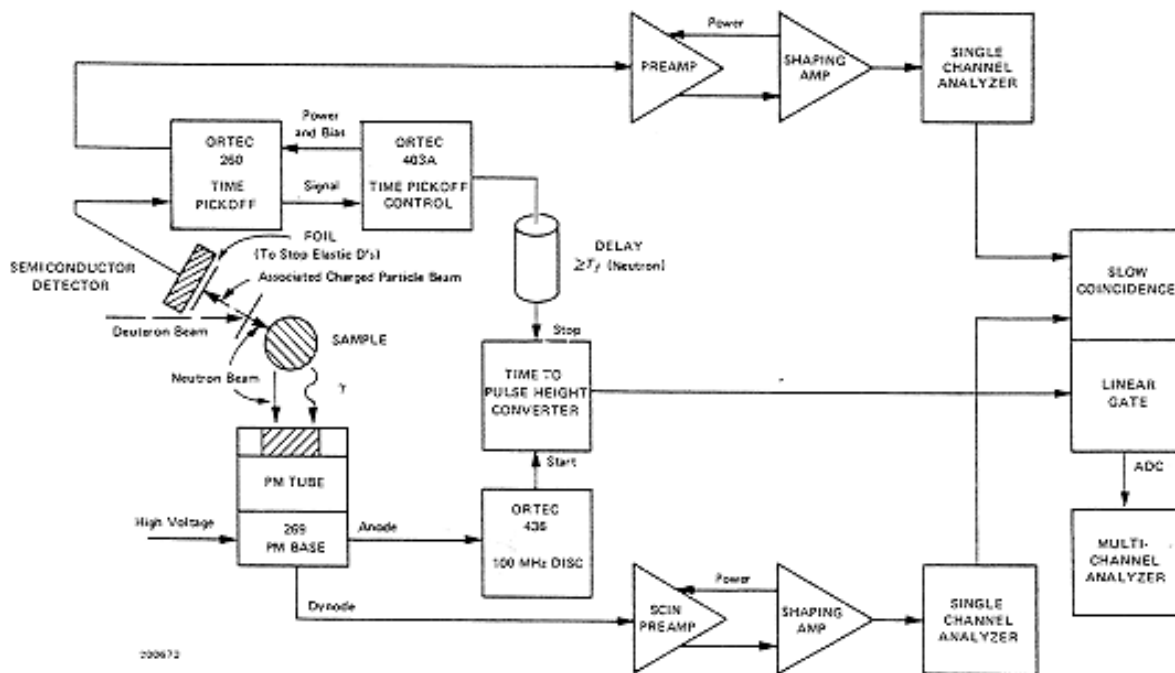

Fig. 4.10. Associated-Particle-Neutron Time of Flight System.

#### 4.2.2. Typical Fast-Slow Coincidence Using NaI(Tl)

The block diagram of Fig. 4.1 applies equally well here. The difference in the two systems is the scintillator and its decay characteristic. This decay time constant is 0.25  $\mu$ sec, whereas the same time constant for Naton-136 is approximately 2 nsec. With NaI(Tl), much more total light is produced per equivalent energy event, but the collection of this light is over such a wide period of time, as indicated, that the time resolution is poorer than that of plastic. Figure 4.3 is a typical spectrum taken with a 1.5 x 1.5-in. NaI(Tl) scintillator on one side of the coincidence system.

#### 4.2.3. Fast Coincidence Using Ge(Li-Drifted) Detectors

Some recent experiments have been performed using a 1.5 x 1.5-in. NaI(Tl) scintillator in a gamma-gamma coincidence arrangement with an ORTEC

10-cm<sup>3</sup> Ge(Li-drifted) coaxial detector, as shown in Fig. 4.4. In this case the radiant energy from the source was not collimated at all, so that the time is given by collection from all parts of the detector. The source viewed one end of the germanium detector. Side channels selected the energy region of interest, which was the photopeak on each side. The full time spectrum is given in Fig. 4.5. Full width at half maximum (FWHM) and full width at one-tenth maximum (FWTM) are indicated. Comparison of this spectrum with published timing curves<sup>4</sup> indicates a very good detector design for timing purposes.

The counting efficiencies associated with the FWHM and FWTM points are approximately 60% and 92% respectively.

<sup>4</sup>R.L. Graham et al., *IEEE Trans. Nucl. Sci.* NS-13 (1), 72 (1966).

## 5. MAINTENANCE

Since the ORTEC 269 is composed of only passive components, very little maintenance is expected, mainly replacement of components that have failed with age. Table 5.1 lists approximate dynode voltages for comparative purposes for use at this

time. Almost all failures of the divider string may be isolated by removing the PM and making these measurements. Potentiometer R-26 was set fully clockwise for the voltages given in Table 5.1.

Table 5.1

Pin No.	Typical Voltage (V)	Pin No.	Typical Voltage (V)
20	Set to -3 kV or max out of PS	5	-1750
19	Should vary from -2750 V to -3 kV W/R17	14	-1625
1	Should vary from -2525 V to -2750 V W/R15	6	-1500
2	-2525	13	-1325
17	-2400	7	-1200
3	-2275	12	-1000
16	-2125	8	-750
4	-2000	11	-475
15	-1875	10	-0

