

Spectroscopy systems for ORTEC instrumentation produce pulse height distributions of gamma ray or alpha energies. MAESTRO-32 (model A65-B32) is the software included with most spectroscopy systems and includes a control program for ORTEC hardware commonly referenced as the UMCBI. The UMCBI provides all the drivers for the various hardware MAESTRO-32 supports. MAESTRO-32 is an emulation software package that provides a histogram display for pulse heights as well as utilizing the PC for display and control functions that would normally be done in older stand alone multi-channel pulse height analyzers. Functions in MAESTRO-32 are typically designed for germanium detector spectra and functions like "peak search" are looking for narrow peaks found with a germanium detector not the broad peaks found with a sodium iodide [NaI(Tl)] detector. Software packages for qualitative and quantitative analysis of gamma rays are available for both germanium, sodium iodide, and alpha spectra. Specialized application software packages are also available.

Processing pulse height information can be recorded in three ways. One method is where the output of an analog shaping amplifier feeds into an ADC. A second method is by using a DSP instead of an analog shaping amplifier. The detector preamplifier output is sampled, digitized, and filtered. Then the digitized information is displayed as a histogram. The third way is to list each pulse height event sequentially (List Mode). List mode requires the use of our software toolkit (Model A11-B32) to write a program for List Mode operation. Example programs are provided in the manuals of instruments that have list mode capability.

Detectors

High-Purity Germanium Detectors (HPGe)

Germanium detectors are extremely large reverse biased diodes which include charge sensitive preamplifiers that convert the charge deposited by interacting gamma radiation into a voltage pulse which is typically filtered and amplified for display in a pulse height histogram to exhibit the energy spectrum of the gamma-rays collected. Germanium detectors are well known for their superior resolution. A typical NaI detector would have on the order of 7% resolution while an HPGe detector would have less than 0.13%. A full line of HPGe detectors is available from ORTEC including planar and coaxial configurations. HPGe detectors need to be cooled to near liquid nitrogen temperatures to operate. HPGe detectors far exceed any other detector type for gamma-ray resolution. HPGe technology has grown extensively over the past ten years. Today both laboratory and field units are available with full analysis capability with either liquid nitrogen or with refrigeration cooling systems.

Thallium Activated Sodium Iodide [NaI(Tl)] Detectors

NaI(Tl) detectors incorporate a NaI(Tl) crystal mounted on a photomultiplier tube (PMT). The NaI(Tl) crystal emits a flash of light proportional to the energy of the gamma ray that interacts with the crystal. The PMT detects this light and amplifies the detected light to yield a proportional quantity of charge. This charge is converted into a voltage pulse by a charge sensitive preamplifier. The pulse can be discriminated by a window type (upper and lower level) Single Channel Analyzer (SCA) and then counted, or these pulses can be displayed as a histogram of pulse heights representing a spectrum of energy.

Other Scintillator detectors are available today such as BGO, CsI, Fast Plastic, etc. Halide detectors have resolutions about twice as good as NaI detectors (around 3%) which make this an attractive detector for some applications. It is important to note that HPGe detectors still have more than 20 times better resolution than the halides can provide.

Alpha Detectors

Alpha detectors are charged-particle silicon crystal diodes that come in various active diameters. There are two types of detectors for alphas. The Ultra series detectors have an ion-implanted front contact that gives a very thin (~500 Angstrom silicon equivalence) front contact and these have passivated leakage surfaces. These detectors are available as low background (designated as "AS") detectors that will fit into ORTEC vacuum chambers. Ultra series detectors require positive bias voltage.

The "ruggedized" or "R" series detectors are made with metal evaporated contacts and have a contact thickness on the order of ~2300 Angstroms silicon equivalence. These detectors have epoxy covered leakage surfaces. These detectors are available as low background (designated as "SNA") detectors that will fit into ORTEC vacuum chambers. R-series detectors require negative bias voltage.

Processing Electronics

Preamplifiers

HPGe detectors come with a charge-sensitive preamplifier that integrates the charge from the gamma-ray interaction in the detector crystal onto a capacitor in the feedback circuit. Either a parallel resistor or a reset switch (transistor or LED diode switch) discharges the capacitor.

NaI (Tl) detectors use a charge-sensitive preamplifier that is stand-alone or incorporated into the PMT base.

Alpha detectors also use a charge-sensitive preamplifier that is stand-alone or incorporated into the alpha system.

Research Applications

Pulse-Height, Charge, or Energy Spectroscopy

Analog Shaping Amplifiers

Shaping amplifiers have a selectable shaping time, t_s ($2.2 \times t_s = \text{risetime}$) which shapes the detector pulses for best resolution or throughput, a pole zero circuit that allows the pulse to return to base line long before the actual preamplifier charge pulse does, and a base line restorer circuit to insure a consistent reference for the pulse heights. Some shaping amplifiers incorporate logic to account for preamplifier reset time, pulse processing time, and pile-up rejection circuits to correct for dead times that the amplifier processing produces. See the Amplifier section for more information.

Multi-Channel Analyzers

Multi-Channel Analyzers take their input from an analog amplifier and digitize the incoming pulse heights placing the accumulated data into memory and displaying this pulse height distribution in a histogram. The histogram X-axis is the pulse height and the Y-axis is the number of counts. Today's Multi-Channel Analyzers typically consist of a Multi-Channel Buffer (MCB) which has an Analog-to-Digital Converter (ADC) and a histogramming memory that can be interfaced to a PC for display. Software (MAESTRO-32 model A65-B32) is required to run the MCB units using the computer to make a complete Multi-Channel Analyzer. The interface to the PC can be either by thinwire ethernet, parallel printer port, dual port memory, or USB. The number of channels in the ADC can determine the digital resolution which should be chosen to suit the detector type and energy range. Signal processing does take time and the time the system is available to receive a signal is considered "Live Time" while all the time consumed with signal processing is "Dead Time". MCA systems can receive logic signals to determine this "Dead Time" in order to insure any quantitative data is correct.

DSP Units

Digital Signal Processor (DSP) units replace the functions of the analog shaping amplifier and the MCB. These DSP units also use MAESTRO-32 software (included with all DSP models). DSP units typically receive a signal with a specific shape from the preamplifier. This signal is sampled and the resulting digital number is processed to provide a much larger range of shaping parameters than an analog amplifier can provide. The functions of gain, baseline restorer, pole zero, and dead time logic functions are still performed in the DSP. Since the data is already digitized an ADC is not required. A histogram is typically made for display on the PC. The DSP units interface with a PC either with a dual port interface, a thinwire ethernet interface or a USB interface (see the individual data sheets for details).

Examples

Figures 1 through 8 show systems for pulse-height spectrometry with a variety of detector types. The following types are included:

Microchannel plate detector (Fig 1).

Microchannel plate photomultiplier tube (Fig. 1).

NaI(Tl) scintillation detector (Fig. 2).

Conventional photomultiplier tube (Fig. 3).

Proportional counter (Fig. 4).

Silicon charged-particle detector (Fig. 5).

Si(Li) detector (Fig. 6, 7 and 8).

Ge detector (Figs. 6, 7, and 8).

If nuclear or x-ray radiation is being detected, the pulse-height is usually calibrated in terms of the energy of the radiation. Hence the term "energy spectroscopy" is used. For other types of signal sources, the pulse height simply represents the charge deposited in the detector by the event. Consequently, the measurement process can be considered to be either "charge" or "pulse-height" spectrometry. In Figures 1, and 3 through 7, a preamplifier integrates the charge deposited in the detector, an amplifier shapes the pulses for pulse-height measurement, and a multichannel buffer (ADC plus memory) sorts the pulse heights into a spectrum (histogram of energy versus counts). Figure 2 uses an integrated package complete with preamplifier, high voltage supply, and a digital signal processor all powered by the USB interface to the PC.

In Figure 4, the low-noise 142PC Preamplifier has about a factor of 6 higher sensitivity than the standard 142IH Preamplifier. This higher sensitivity allows operation of the proportional counter at a lower gas gain. The benefit is less dependence of the gas gain on counting rate in the proportional counter. As a result, the proportional counter can be operated at higher counting rates before peak shifting occurs in the recorded energy spectrum.

In Figure 6, connection of the BUSY and PUR signals between the amplifier and MCB is essential for achieving accurate dead time correction with the Gedcke-Hale Live-Time Clock in the MCB.

Research Applications

Pulse-Height, Charge, or Energy Spectroscopy

Figures 2, 7 and 8 show the use of an integrated electronics package for x-ray or gamma-ray spectrometry. In this case the preamplifier output is sampled and our digital systems provide digital signal processing for improved performance.

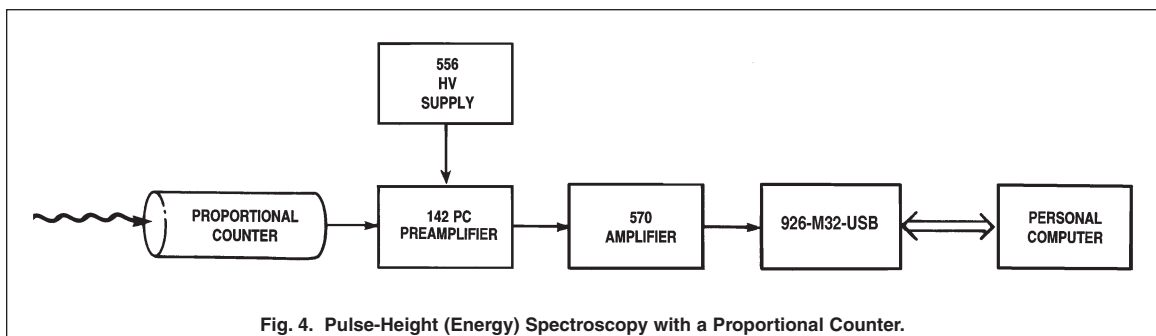
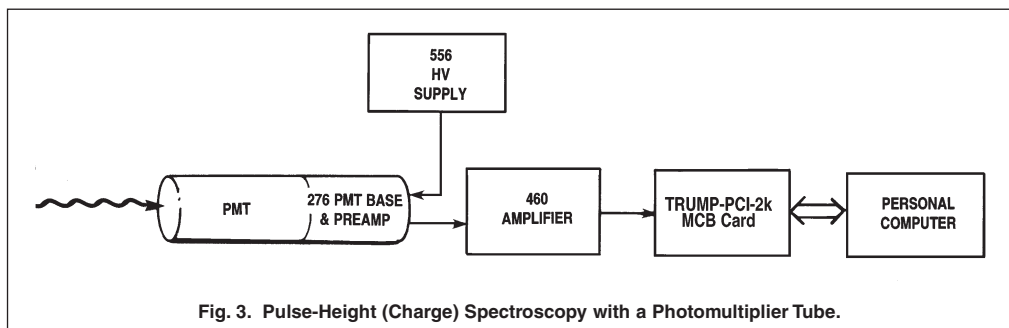
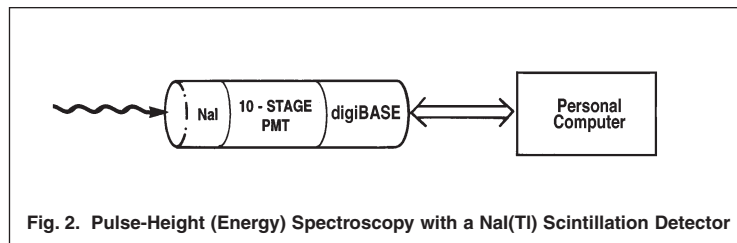
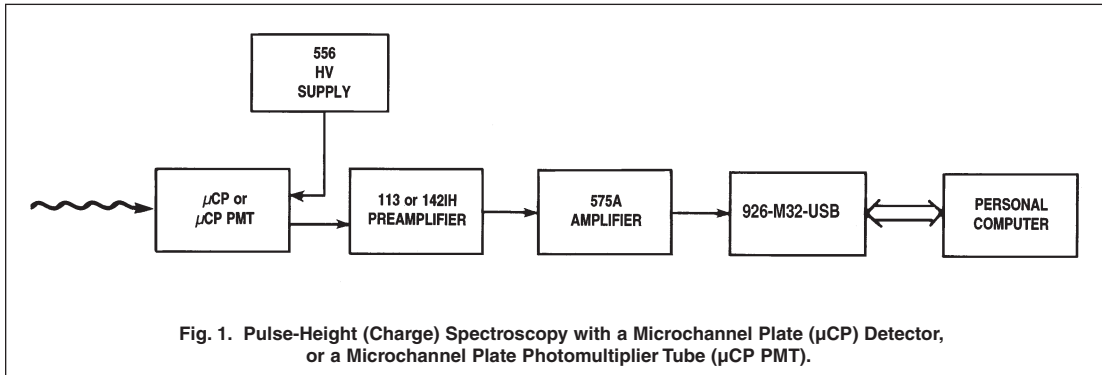

Research Applications

Pulse-Height, Charge, or Energy Spectroscopy

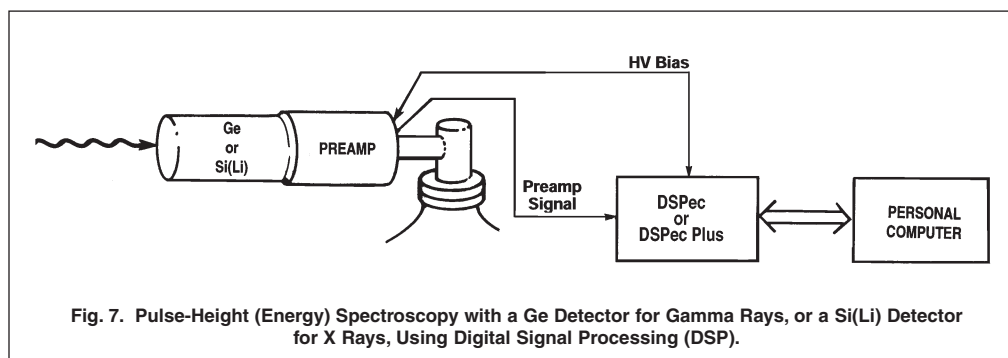
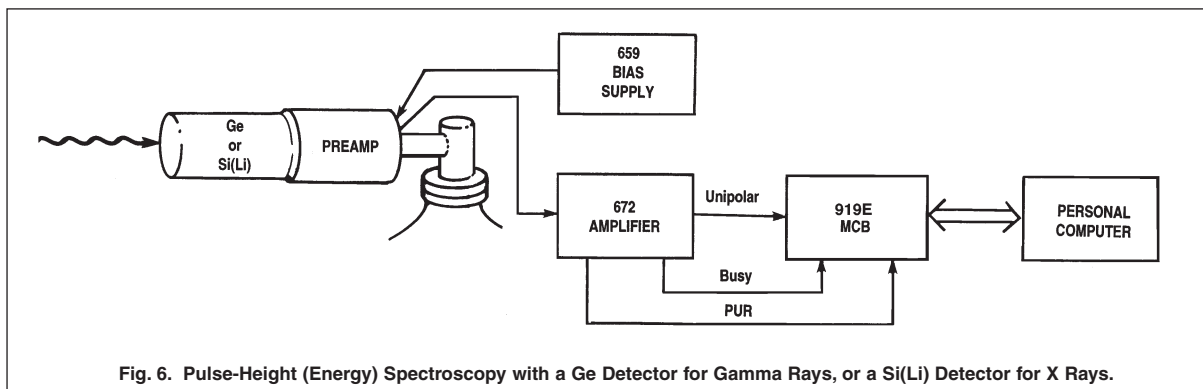
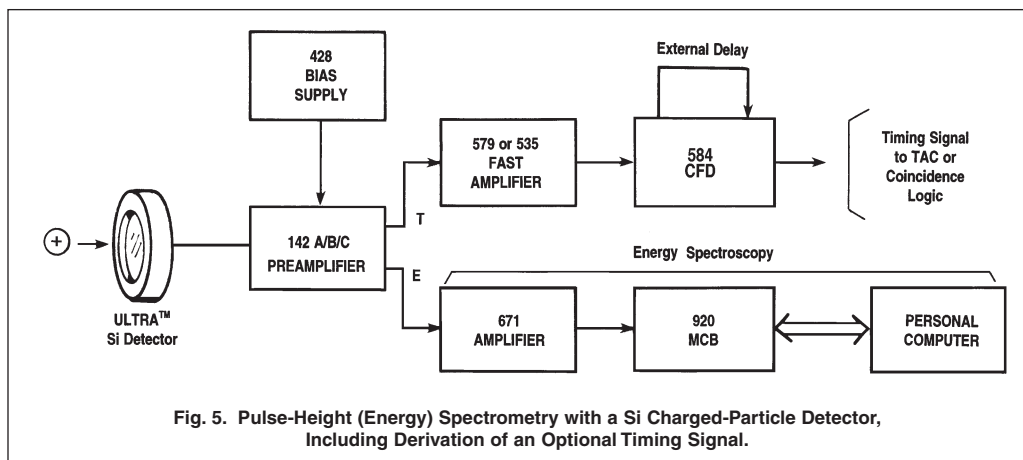

Research Applications

Pulse-Height, Charge, or Energy Spectroscopy

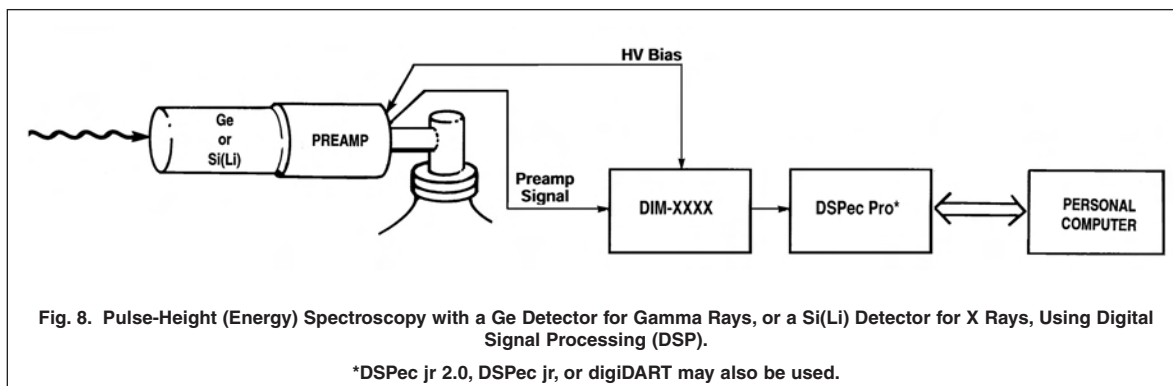

Specifications subject to change
071309

ORTEC[®]

www.ortec-online.com

Tel. (865) 482-4411 • Fax (865) 483-0396 • ortec.info@ametek.com
801 South Illinois Ave., Oak Ridge, TN 37831-0895 U.S.A.
For International Office Locations, Visit Our Website

AMETEK[®]
ADVANCED MEASUREMENT
TECHNOLOGY