

A Portable HPGe System for Measuring Contaminated Soils and Floors

Richard Hagenauer

**PerkinElmer Instruments / ORTEC®
Oak Ridge, TN**

Introduction

Decontamination and decommissioning (D & D) requires the characterization of large surface areas such as soils, walls, and floors. To address the identification and quantification of radioactive material in these problematic surroundings, a portable high-resolution gamma-spectrometry system has been developed. The system was tested using the calibrated concrete slabs at Grand Junction, Colorado. The results show good agreement between the given values and the assigned values for nuclides commonly found in soil.

The complete *in situ* system, called the ISO-Cart^a system, includes a high-purity germanium detector (HPGe), mobile cart with specialized collimator/shield assembly, ORTEC DART[®] portable MCA, and GammaVision[®]-32, and ISOTOPIC¹ data acquisition and analysis software. Gamma-ray spectra, acquired using high-resolution gamma-ray spectroscopy, are processed first by the GammaVision program, and then by ISOTOPIC. Corrections are made for geometry, attenuation in the matrix (soil, walls, and floors), and self-absorption. The final ISOTOPIC report lists the quantity of each radionuclide in units of grams and activity. The detector is calibrated using only an NIST-traceable point source positioned 30 cm from the detector face. Other standards may be necessary to *validate* the measurement-analysis system. No additional standards or Monte Carlo simulations are necessary.

The ISO-Cart system, presently used for general-purpose *in situ* measurements, can also be used for measurement of radioactivity in soil which may contain radioactivity from natural sources, fallout, or from a radioactive spill. Traditional soil-sampling techniques require long analysis times, are very labor intensive, and are associated with significant sampling error. By contrast, the ISO-Cart can make *in situ* measurements over a wide area at once, yielding a significant reduction in sampling error. In combination with the short analysis effort required, the ISO-Cart provides a very cost-effective alternative to soil sampling.

Description of Measurement Method

The ISO-Cart was configured with an 80% GMX (n-type) detector with a portable Dewar with a 48-hours holding time for liquid nitrogen. The detector was used with and without a collimator in order to collect two sets of results for comparison. The spectra were collected in the DART, which contains the HV supply and signal-processing electronics. The data collection was controlled with a laptop and GammaVision software. Power for the DART and laptop was provided by the auxiliary battery pack on the ISO-Cart. The data were acquired for 2000 seconds.

^aISO-Cart[™] is a trademark of PerkinElmer Instruments.

Description of Spectrum Analysis

The ISOTOPIC program runs in conjunction with GammaVision for HPGe detector gamma-ray analysis. GammaVision controls the acquisition, saves the spectrum, and performs the peak analysis. ISOTOPIC then “post-processes” the results further to correct for the matrix, container, collimator, and geometry effects using operator-supplied information about the dimensions, weights, distances, and materials, along with internal collections of databases of geometry and matrix correction information. The program is menu driven with selection by a mouse. Hard-copy reports are available for summaries including gram and activity quantities of each nuclide, ^{235}U enrichment, peak-area corrections, MDA values, and components of error estimates.

Deciding on Collimation

When no collimator is used the field-of-view is 10×10 m. This application is practical for low-background measurements over wide fields. The patches selected for measurement can be continuous, random, or systematic. This technique is helpful for initial surveys over wide areas and provides more thorough sampling information than soil sampling using core-drilling techniques.

In areas of high background or well-defined contamination locations such as a concrete floor or a localized spill on the soil, a collimator (with 2.54 cm of collimation) can be used to reduce the field-of-view to 3×3 m. If there is one very hot spot, the measurement is configured as a point source. In general, collimation should be used when the activity is known to be restricted or ambient background is high. When collimation is used, measurement sensitivity is reduced by a factor of 2 to 4 depending on the energy of the gamma ray.

Configuring the Measurement

This configuration information is used to provide the attenuation correction for the soil and the geometry corrections. The HPGe detector is positioned 1 m above the soil. The measurement area is divided into squares of either 3×3 m or 10×10 m. The depth of the soil “box” is determined by the “infinite thickness”^b of the material to the highest-energy gamma rays used for the nuclide reference. For example, for ^{40}K the infinite thickness for soil of density 1.6 g/cc is about 0.7 m. There is no advantage in configuring the “box” any deeper because the gamma rays cannot significantly penetrate. Within ISOTOPIC there is a provision for modeling the measurement setup. A diagram of a measurement configuration is shown in Fig. 1, and the corresponding configuration description shown in Fig. 2.

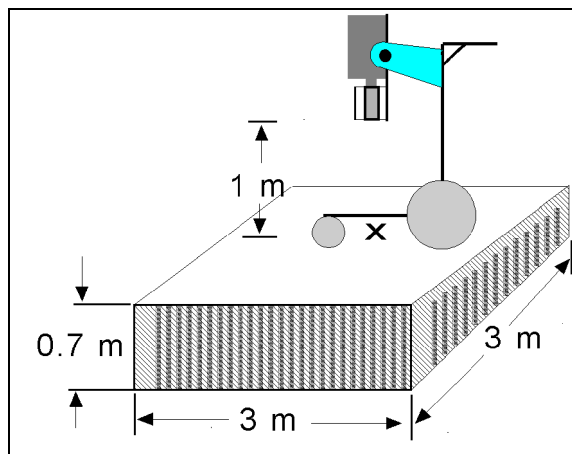

Fig. 1. Position of ISO-Cart using a collimator.

^bInfinite thickness is the thickness through which 99.9% of the gamma rays of the designated energy are absorbed.

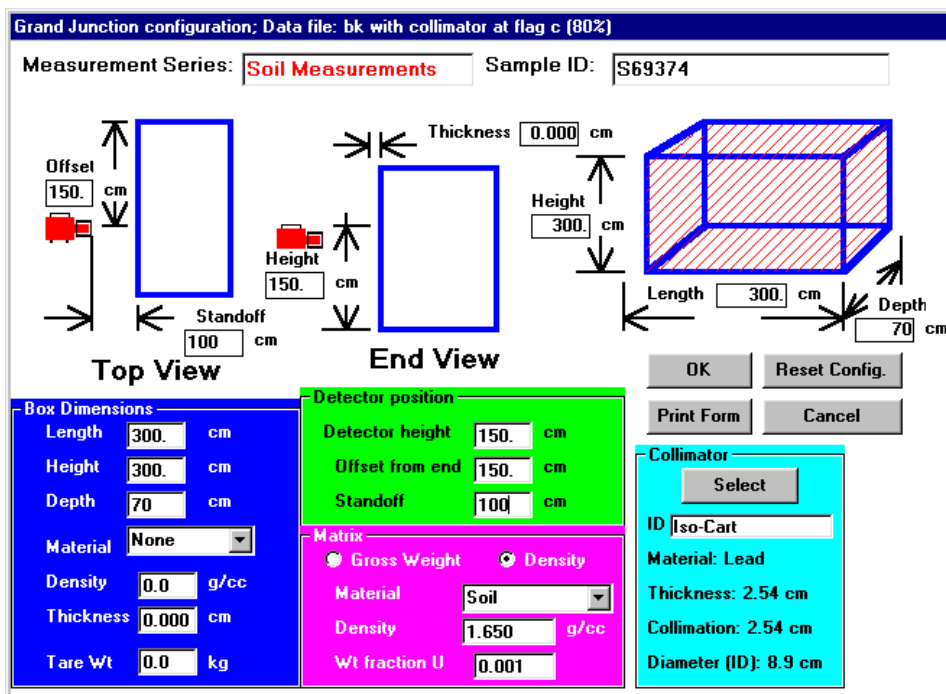

Fig. 2. Configuration page in ISOTOPIC used to model the measurement.

Fine-Tune Adjustments

The average density of soil may not be what the gamma rays “see” as they penetrate the soil. Program ISOTOPIC has a unique feature that allows the user to fine tune the corrections factors for matrix. When peak areas are corrected for branching ratios, matrix, and container attenuations, the peak areas for all the peaks for each nuclide should be similar. If the matrix density is incorrectly assigned there will be a trend in corrected peak areas with energy. An intense, high-energy gamma ray may be assigned as an arbitrary reference point. If the matrix attenuation is inadequate then a slope. ISOTOPIC lets the user correct the attenuation dynamically as shown in Figs. 3 and 4. When the slope is reduced to zero, the correction factors are proper.

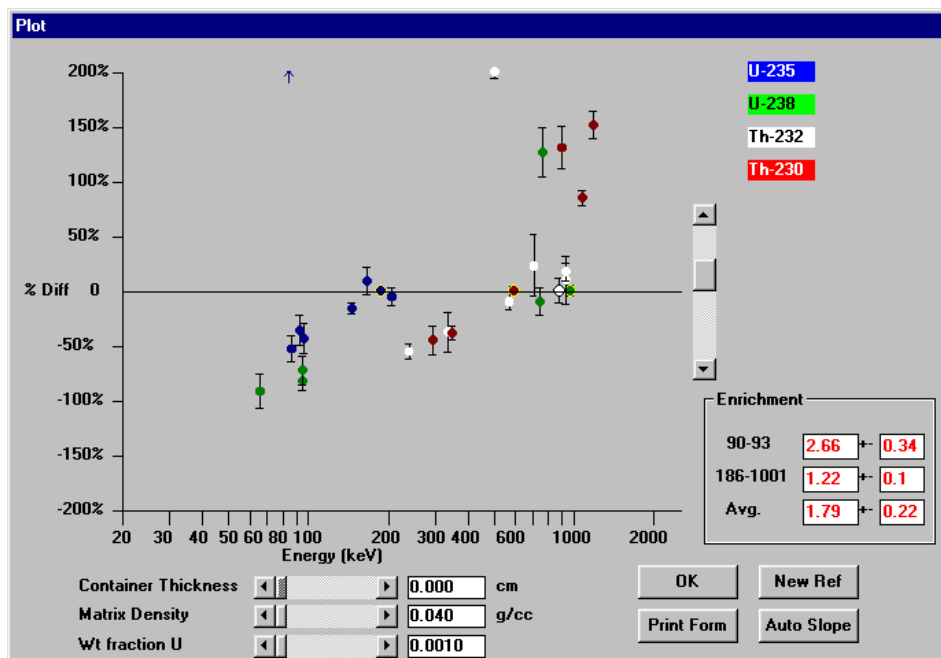

Fig. 3. An example of an under corrected analysis.

Making Measurements When Soil Sampling Is Available

Results from soil samples taken earlier can complement the ISOTOPIC results. If radioactivity has seeped into the soil to a depth determined by soil sampling, then improved results may be obtained if this configuration is treated as if there is a soil “container” covering the radioactive soil. This “container” is configured as glass, which has an average atomic number similar to soil. The density assigned to this “container” is the same as the soil density. The soil top containing no radioactivity is then treated as a “slab attenuator.” Density values obtained from core samples of soil also provide an accurate value for the soil density. (Bear in mind that the uncertainties in the matrix density and matrix thickness that the gamma rays “see” are the major sources of error in soil sampling.)

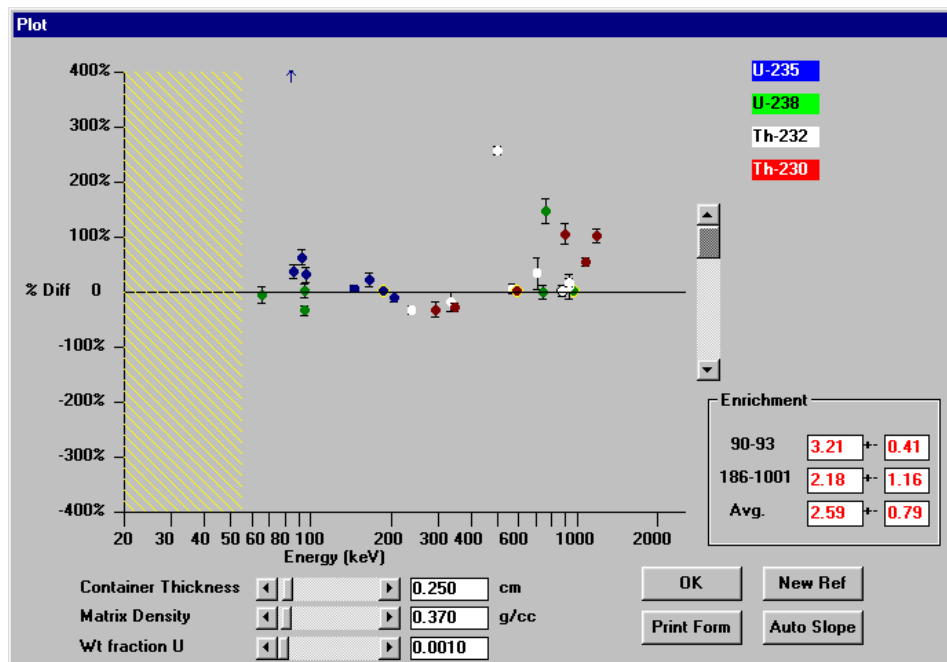

Fig. 4. An example of a properly corrected analysis.

Selection of ORTEC Software

An associated ORTEC product, M-1, exists for performing *in-situ* soil assay. This system employs an uncollimated detector and uses algorithms devised at the DOE EML laboratory³ to compute activities per unit mass or area, based on specific detector physical data and EML-derived formulas. M-1 is designed to compute average contamination over wide areas (infinite-plane geometry) and can allow for exponential “washed-in” distributions characteristic of radioactive fallout. ISOTOPIC, on the other hand, is intended for localized measurements. M-1 was not used in this comparison.

Results and Conclusions

An exercise was conducted at Grand Junction, Colorado, in October, 1999. Five concrete pads with known amounts of radioactivity were measured for ^{226}Ra , ^{232}Th , and ^{40}K using the ISO-Cart *in situ* measurement system described above. These pads are well characterized.² The following results, with and without a collimator, are shown in Table 1. These results show good agreement between the accepted values and the measured results. No significant bias was evident.

In conclusion, the newly developed ORTEC ISO-Cart system provides the data and the analysis necessary to quantify radioactive constituents in soil or other contaminated surfaces. The ISO-Cart

system can quantify contamination either without a collimator for wide-area measurements or with a collimator for localized measurements. Excellent results can be obtained either way. This system is a valuable and effective measurement tool for D & D activities.

References

1. Hagenauer, R.C., "Nondestructive Assay Quantification of Poorly-Characterized Radioactive Isotopes," *Proceedings of the 4th Nondestructive Assay and Nondestructive Waste Characterization Conference*, Salt Lake City, 1995.
2. Leino, R., et al., "Field Calibration Facilities for Environmental Measurement of Radium, Thorium, and Potassium," June, 1994, DOE/ID/12584-179.
3. Helfer, I.K and Miller, K.M., "Calibration Factors for Ge Detectors Used for Field Spectrometry," *Health Physics*, Vol. 55, No. 1 (July) pp. 15–29, 1988.

Table 1. Comparison of Measured Results with Assigned Results

Measurement of calibration pads using the ISO-Cart hardware Isotopic software with collimator

Pad ID	Ra-226 (pCi/g)					Th-232 (pCi/g)					K-40 (pCi/g)				
	Assigned	±	Measured	±	% Diff.	Assigned	±	Measured	±	% Diff.	Assigned	±	Measured	±	% Diff.
1	0.82	1.02	0.85	0.25	3.54	0.67	0.12	0.87	0.26	29.25	12.67	0.72	10.90	3.27	-13.97
2	1.92	1.54	1.94	0.58	1.04	0.87	0.12	0.64	0.19	-26.44	45.58	1.82	44.36	13.31	-2.68
3	1.70	1.38	2.05	0.61	20.59	4.92	0.26	4.11	1.23	-16.46	17.07	0.82	20.30	6.09	18.92
4	12.07	5.64	13.80	4.14	14.33	1.04	0.12	1.60	0.48	53.85	17.56	0.98	28.80	8.64	64.01
5	8.36	1.91	7.42	2.23	-11.24	1.91	0.16	1.79	0.54	-6.28	34.68	1.46	36.50	10.95	5.25

Measurement of calibration pads using the ISO-Cart hardware Isotopic software without collimator

Pad ID	Ra-226 (pCi/g)					Th-232 (pCi/g)					K-40 (pCi/g)				
	Assigned	±	Measured	±	% Diff.	Assigned	±	Measured	±	% Diff.	Assigned	±	Measured	±	% Diff.
1	0.82	1.02	0.92	0.28	12.07	0.67	0.12	0.92	0.28	36.87	12.67	0.72	14.80	4.44	16.81
2	1.92	1.54	1.97	0.59	2.60	0.87	0.12	1.08	0.32	24.14	45.58	1.82	51.00	15.30	11.89
3	1.70	1.38	1.91	0.57	12.35	4.92	0.26	4.86	1.46	-1.22	17.07	0.82	17.30	5.19	1.35
4	12.07	5.64	9.94	2.98	-17.65	1.04	0.12	1.34	0.40	28.85	17.56	0.98	24.20	7.26	37.81
5	8.36	1.91	7.57	2.27	-9.45	1.91	0.16	2.78	0.83	45.55	34.68	1.46	44.30	13.29	27.74