

# Performance of a Multi-Spectrum Assay System for Large Containers

Ronald Keyser, Timothy Twomey and Richard Hagenauer

ORTEC, 801 South Illinois Avenue, Oak Ridge, TN 37831

## **Abstract:**

*The radionuclide analysis of large bulk samples (1 to 30 m<sup>3</sup>) of potentially inhomogeneous material is limited by several factors including the absorption correction for the material in the volume. The volume could be a waste container, a pipe or duct, building surfaces (walls), or a soil area. While there may be some knowledge of the chemical processes involved which produced the waste or performed in the building or structure which became the waste to be measured, there is little knowledge of the bulk material present. To make a simple, but reasonably accurate determination of activity, a multi-measurement system including hardware and software has been developed. The multiple measurements from either multiple detectors or multiple positions of a single detector are combined to produce a single result for the radioactive content of the bulk sample. The absorption correction and geometry correction in the analysis are based on modeling any container and its content using an empirically-determined efficiency for the HPGe detector. The container absorption can be adjusted automatically or manually to improve the activity and concentration results over the initial container and content conditions.*

*Several different geometries, including 50 and 200 l barrels have been measured. The results of the 50 l barrel measurements, complete with uncertainty, are compared with the known contents and shown to be in good agreement. Repeated measurements were made of two geometries to compare the calculated uncertainty with the distribution of measurement results. The distribution of results show a better precision (excluding inhomogeneity) than predicted by the modeling.*

**Keywords: Waste characterization, radionuclide analysis, HPGe spectra, multiple-detector systems, bulk material analysis**

## **1. Introduction**

The radionuclide analysis of large bulk samples is being used to characterize the contents of containers prior to disposal as a means of ensuring that waste is correctly sentenced. The contents are potentially inhomogeneous with widely varying composition. Also, the radioactive material is usually not known. Assumptions can often be made on the contents in order to model or calculate the absorption of the emitted radiations by the sample

To make a simple, but reasonably accurate determination of activity, a multi-measurement system including hardware and software has been developed. The multiple measurements from either multiple detectors or multiple positions of a single detector are combined to produce a single result for the radioactive content of the bulk sample. The absorption correction and geometry correction in the analysis are based on modeling any container and its content using an empirically-determined efficiency for the HPGe detector.

## **2. Equipment**

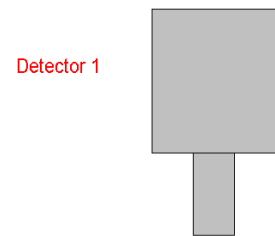
The sample was a 50-liter drum, 31 cm diameter and 63.5 cm high filled to a height of 39 cm with commercial grade potassium chloride. The sample was uniform so it was not necessary to rotate the drum during spectrum acquisition. The <sup>40</sup>K content of natural potassium chloride is 16.2 Bq/gm.

The ISO-Plus system with two ISO-Carts and detectors was used to collect the data. One detector was a 45% relative efficiency ORTEC GMX (N-type) detector. The other detector was a 90% relative efficiency ORTEC GEM (P-type) detector. The ISO-Cart is built to hold a collimator, but none were used. The spectra were collected using the ORTEC digital signal processor (DSP) based MCAs: digiDART and DSPEC jr. The system showing only one detector is shown in Fig. 1. No back shields or other shields were used. The system was located in a room below ground with concrete walls, floors and ceilings.

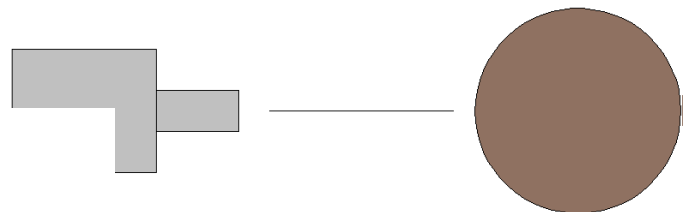


Figure 1. The ISO-Cart system for drum scanning.

The two detectors were positioned such that the axis of the detector was on a diameter of the container and at 90° apart as viewed from above the container. The arrangement is shown in Fig. 2. One detector was positioned such that the detector height was at the midpoint of the container height. The other detector height was at the midpoint of the fill height. The distances are shown in Fig. 3.



Detector 2



The Positions of the Two Detectors.

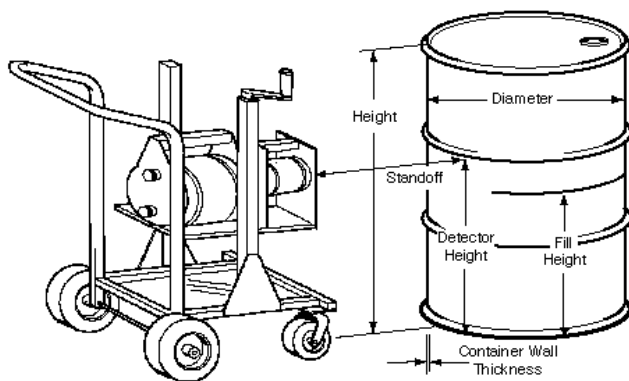
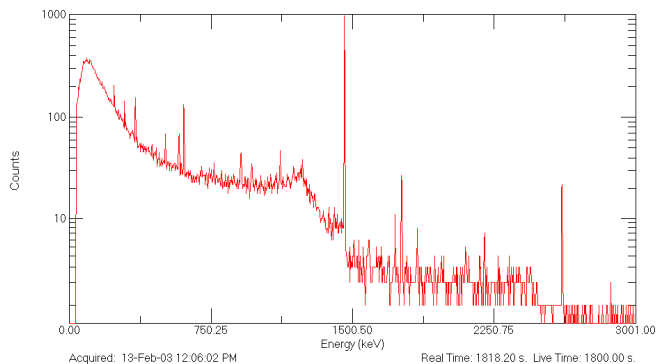


Figure 3. The Measurement Distances.

A typical spectrum is shown in Fig. 4. The background spectrum is shown in Fig. 5. Note that the  $^{40}\text{K}$  is present in significant amounts in the background, as well as other natural emitters. To compensate for the  $^{40}\text{K}$  contribution from the background, the sample data were corrected for this background in the analysis software.

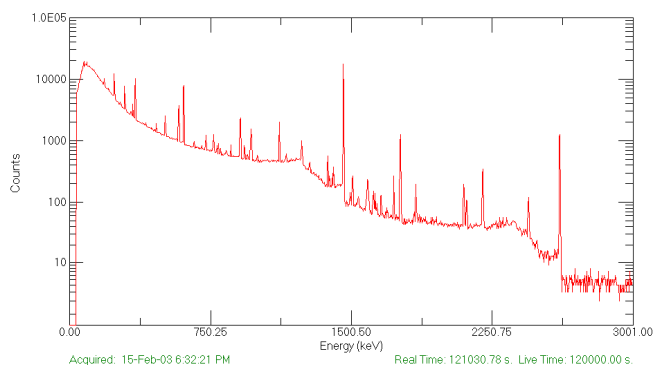


**Figure 4.** Typical Spectrum of Unshielded Potassium Chloride.

### 3. Method

The LANL PDP drum intercomparison program [1] requested participants to make repeated measurements of the drum to assess the uncertainty of the results. This could be done by multiple acquisitions without mechanical change or by sample movement between the spectrum acquisitions. Other tests of the program are described elsewhere [2, 3].

In a similar manner, several sets of measurements were made. In the first set of measurements, the GEM detector was fixed at a distance of 30 cm standoff and at the container midpoint. The GMX detector was set at the fill height midpoint and the standoff was changed from 30 cm to 100 cm in 10 cm steps. Each position was counted more than once. Sufficient counts were collected in the peak region to reduce the counting uncertainty to less than 1%.



**Figure 5.** The Background Spectrum.

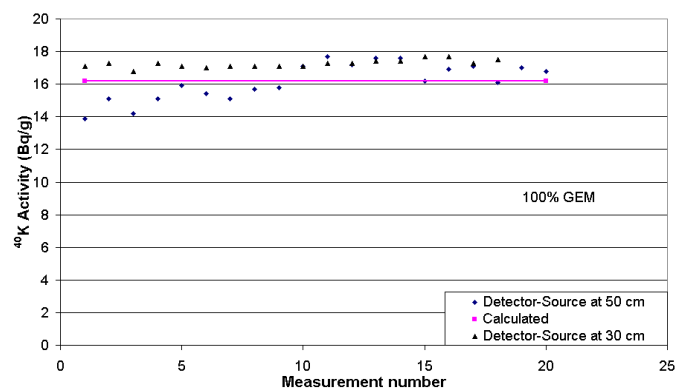
In the second set of measurements, the GMX detector was held at 50 cm distance and the GEM detector was moved from 30 to 100 cm in 10 cm steps. The sample was moved between the first and second sets of measurements.

Additional measurements were taken with the detectors closer to the container.

The analysis software computes the uncertainty for each activity value. The reported uncertainty value includes the counting uncertainty, the calibration uncertainty and the geometry, absorption, and matrix modeling uncertainty. The model uncertainty is based on an unknown matrix with inhomogenous source distribution and is about 30% for the 50 liter drum.

### 4. Results

Figure 6 shows the GEM (container mid point) repeated measurements at 30 and 50 cm without sample change. The mean value for the 30 cm data is 17.3 Bq/g with a standard deviation of 0.31. The mean value for the 50 cm data is 16.2 Bq/g with a standard deviation of 1.1. This is in good agreement with the calculated value (16.2 Bq/g). Normally, the software would average the individual detector results and record the average. In these data, only the individual detector results were used.



**Figure 6.** Replicate Measurements for the Same Standoff.

Figure 7 shows the GMX (sample mid point) repeated measurements without sample change. The mean activity is 17.6 Bq/g with a standard deviation of 0.65. Note that these two sets of measurements essentially show the standard deviation without a contribution of the model uncertainties since these are constant for all the measurements.

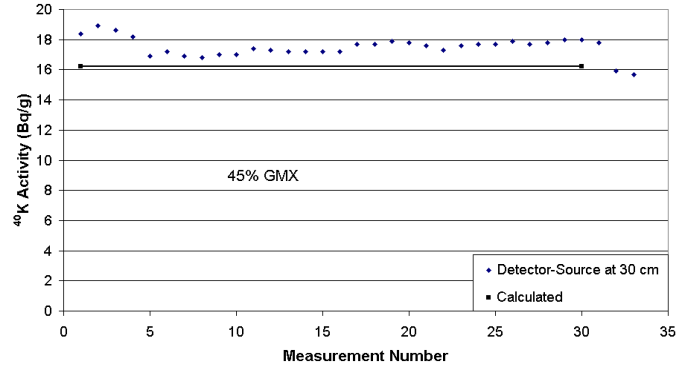


Figure 7. Replicate Measurements for the Same Standoff.

Figure 8 shows the GEM detector results as a function of the detector standoff. The detector height was maintained at the container midpoint. Note that the activity decreases at the high standoff values. The first set of measurements was repeated after moving the detectors and the containers and repositioning in the same geometry.

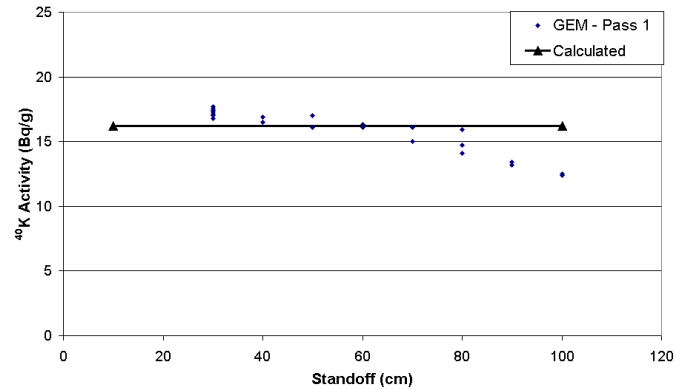


Figure 8. Activity as a Function of Standoff.

Figure 9 shows both sets of data. Note that the data sets are within 25% over the distances of 10 to 100 cm.

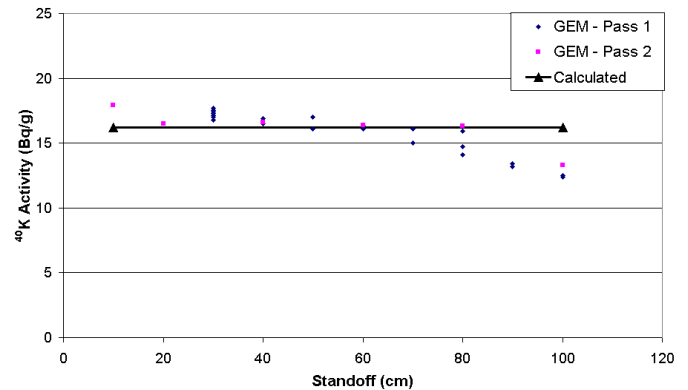


Figure 9. Activity as a Function of Standoff - Repeated.

Figure 10 shows the GMX detector results as a function of standoff. The detector height was maintained at the mid-fill height. Note that the activity is constant as a function of the standoff. This series was repeated as described above. In this case, the data are all within 5% of the average.

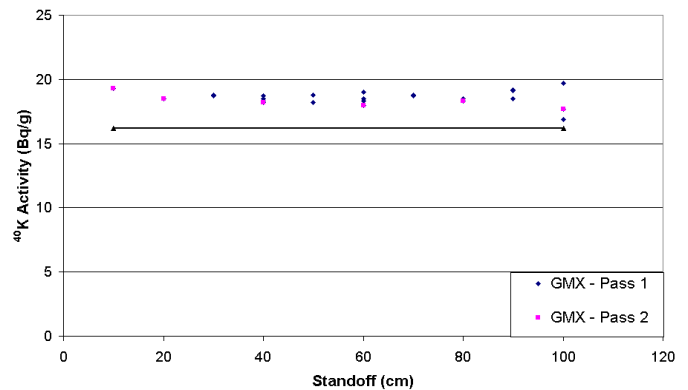


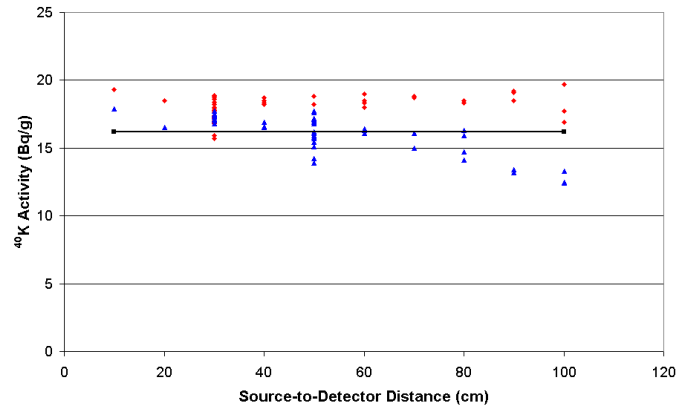
Figure 10. Activity as a Function of Standoff.

Figure 11 shows all the measurements on a single graph. The mean value is 17.3 and the standard deviation is 1.4. These measurements include several different geometry corrections and two different detectors giving a better estimate of the uncertainty of the measurement results as desired in the PDP tests.

## 5. Conclusions

From these results, the following generalizations can be made: the same-geometry repeatability is very good (high precision); the accuracy is good; the standard deviation is on the order 10% or well below the expected uncertainty for this type of measurement; the results are less sensitive to changes in standoff

when the detector height is centered on the fill height rather than on the mid-container height, the detector should be placed at the recommended distance so the Field of View matches the container; and for natural nuclides, the PBC correction is necessary, unless the container is well shielded from the background.



**Figure 11.** The Activity Distribution for All Measurements.

## References

1. K. Greutzmacker, J. Juzminski, S. C. Myers, *Low-Level Waste Drum Assay Intercomparison Study*, Waste Management 2003 Proceedings, Tucson, Feb 2003
2. R. Hagenauer, P. Funk, N. Pépin, J-L. Dufour, *Evaluation of Software to Non-Destructively Quantify Uranium and Plutonium Samples via Gamma-Ray Spectroscopy at the Joint Research Center in Ispra, Italy*, 25<sup>TH</sup> Annual ESARDA meeting, May 2003.
3. R. Keyser, T. Twomey, and R. Hagenauer, *Practical Solutions to Radioactive Waste Characterization*, 21<sup>ST</sup> Annual ESARDA meeting, May 1999.