

NONDESTRUCTIVE IDENTIFICATION OF CHEMICAL WARFARE AGENTS AND EXPLOSIVES BY NEUTRON GENERATOR-DRIVEN PGNA A

T. R. TWOMEY ^a, A.J. CAFFREY ^b, and D. L. CHICHESTER ^b

^a Ortec Division, Ametek, Inc., Oak Ridge, Tennessee 37831 USA

^b Idaho National Laboratory, Idaho Falls, Idaho 83415 USA

Abstract

Prompt gamma-ray neutron activation analysis (PGNAA) is now a proven method for the identification of chemical warfare agents and explosives in military projectiles and storage containers. Idaho National Laboratory is developing a next-generation PGNAA instrument based on the new Ortec Detective mechanically-cooled HPGe detector and a neutron generator. In this paper we review PGNAA analysis of suspect chemical warfare munitions, and we discuss the advantages and disadvantages of replacing the californium-252 radioisotopic neutron source with a compact accelerator neutron generator.

1. INTRODUCTION

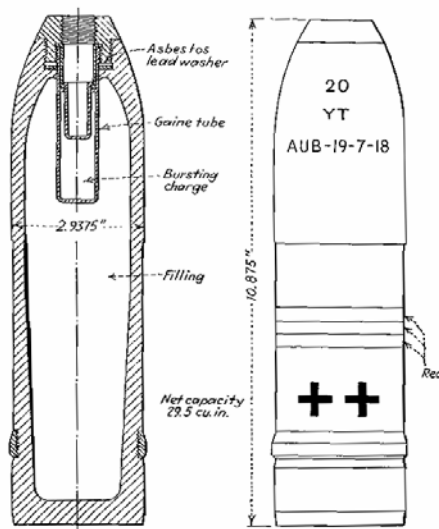

Figure 1: Identification markings of a French World War I-era mustard gas 75-mm artillery projectile.[1]

1.1. The "non-stockpile" munitions identification problem

Worldwide, armies tend to identify artillery and mortar projectiles in their stockpiles by color codes, code letters, and symbols, as depicted in Figure 1. However military firing ranges, old battlefields, and munition disposal sites may contain hundreds to thousands of unexploded projectiles, and over time these "old and abandoned" or "non-stockpile" projectiles lose their identifying markings due to corrosion, as shown in Figure 2. Yet the safe and lawful disposal of non-stockpile munitions requires identification of their fill chemicals, and besides explosives,

these commonly include smoke-generating substances such as titanium tetrachloride and white phosphorus. In addition, in countries where chemical warfare (CW) agents have been stored, tested, or used in battle, the list of non-stockpile munition fill chemicals expands to include blister agents, choking agents, nerve gases, and other CW agents. Finally, many armies train with practice munitions, and practice munition fills include sand, concrete, water/antifreeze mixtures, and plaster-of-Paris.



Figure 2: A 4.7-inch artillery projectile during assessment in the Spring Valley neighborhood of Washington, D.C., January 1993. PGNAA determined this “non-stockpile” projectile contains an incendiary chemical. The projectile was likely buried in 1919.

1.2. A Prompt Gamma-ray Neutron Activation Analysis solution

The prompt gamma-ray neutron activation analysis (PGNAA) technique employs neutron radiation as a probe of an item's fill. Neutrons can easily penetrate the steel casing of a bomb or artillery shell, and they excite the atomic nuclei of the chemicals inside. In turn, these nuclei de-excite by emission of high-energy gamma rays. These gamma rays also penetrate steel to escape the container or munition, and hence their characteristic gamma-ray signature or "spectrum" can be measured with a gamma-ray detector external to the item under test.

As a nondestructive method for both treaty monitoring and the identification of non-stockpile chemical munitions, Idaho National Engineering Laboratory (now Idaho National Laboratory, or INL for short) developed the Portable Isotopic Neutron Spectroscopy (PINS) chemical assay system in 1991.[2,3] PINS is the first PGNAA system designed for identification of chemical warfare agents. Since 1992, PINS instruments have been employed to identify thousands of suspect chemical non-stockpile munitions in worldwide, and it has been calibrated on most types of military explosives and every type of chemical munition in the current U.S. stockpile.[4] Since 1995, PINS has been a commercial product of the Ortec Division of Ametek, Inc.[5]

The first two generations of PINS instruments use a californium-252 radioisotopic neutron source and a liquid nitrogen-cooled HPGe gamma-ray spectrometer. We consider it essential to use a high resolution germanium spectroscopy system to separate the fill chemical signal from the significant background from the munition body. In the case of a 155-mm artillery projectile filled with sarin (GB) nerve agent, the fill chemical mass is 3 kg, while the projectile mass is over ten times greater, 41 kg.

1.3 Neutron generator-based PGNAA instruments for munition fill identification

Recently INL began design of the next generation PINS system, and to simplify logistics for military customers, it will use a modified version of Ortec's Detective mechanically-cooled HPGe detector to eliminate the need for liquid nitrogen cooling. The Detective contains a digital signal processing MCA and sufficient battery power for three hours operation in a compact 10 kg package, as shown in Figure 3.



Figure 3: Ortec Detective mechanically-cooled HPGe detector.

The next generation PINS system will use an electrical neutron generator in lieu of the californium-252 source. INL has evaluated neutron generators from Activation Technology Corp., the All-Russia Institute of Automatics (VNIIA), EADS/SODERN, and Thermo Electron over the past several years; a test of the SODERN Genie-16 neutron generator with an actual chemical warfare munition is shown in Figure 4.



Figure 4: A SODERN neutron generator irradiates a mustard-agent filled 4.2-inch mortar projectile during a test assay at U.S. Army Dugway Proving Ground, September 2003. For safety, the mortar projectile is overpacked inside the air-tight olive-drab steel can stenciled “LEAKER.”

Previously, Lawrence Livermore National Laboratory tested a neutron generator-based PGNAA system for chemical warfare agent identification in 1992,[6] and more recently, Brüker and SAIC have produced commercial PGNAA instruments for explosive and CW agent identification that employ neutron generators.[7,8]

2. PGNAA FOR CW AGENTS AND EXPLOSIVES

2.1 Response of atomic nuclei to neutrons

Nuclear techniques like PGNAA are not sensitive to molecular bonds, and at best they can provide an unknown chemical’s stoichiometric elemental ratios. However, given the limited number of chemical types found in munitions, information on which elements are present and which are absent is often sufficient to accurately infer the identity of the fill chemical.

When the stable, naturally occurring chemicals inside a munition are irradiated with neutrons, their nuclei are promoted to excited states by neutron capture and neutron inelastic scattering reactions. As these nuclei de-excite, they emit characteristic gamma rays, and by measurement and analysis of the resulting gamma-ray spectrum, one can identify the chemical elements present inside the item under test, since the energies and relative intensities of their characteristic gamma rays have been measured and cataloged for all of the naturally occurring elements in the periodic table.[9]

2.2 The elemental composition of chemical warfare agents, explosives, and military smoke chemicals

Many chemical warfare agents are hydrocarbons, as shown in Table 1. The nerve agents GA, GB, GD, and VX are organophosphorus compounds. Agent VX can be distinguished from the G series of nerve agents by the presence of sulfur. The blister agents mustard and lewisite contain no phosphorus, but both contain about 45-50 weight-% chlorine, and lewisite can be distinguished from mustard agent by the absence of sulfur and the presence of arsenic.

Table 1: Elemental composition in weight-% of selected chemical warfare agents.[10]

	Sarin (GB)	Soman (GD)	Tabun (GA)	VX	Mustard (HD)	Lewisite (L)
Hydrogen	7.1	8.8	6.8	9.7	5.0	1.0
Carbon	34.3	46.2	37.0	49.4	30.2	11.4
Oxygen	22.9	17.6	19.8	12.0		
Nitrogen		17.3	5.2			
Fluorine	13.6	10.4				
Phosphorus	22.1	17.0	19.1	11.6		
Sulfur				12.0	20.1	
Chlorine					44.7	51.3
Arsenic						36.1

The one or two letter codes, e.g. GB, are the NATO designations for these agents.

Most explosives contain a few weight-% hydrogen, about 20-40 weight-% nitrogen, approximately 40-60 weight-% oxygen, and a balance of carbon, as illustrated in Table 2.

Table 2: Elemental composition in weight-% of common military explosives.[11]

	Comp. B	HMX	PETN	RDX	Tetryl	TNT
Hydrogen	2.5	2.7	2.5	2.7	1.7	2.2
Carbon	24.5	16.2	19.0	16.2	29.0	37.0
Oxygen	42.8	43.2	60.8	43.2	44.6	42.3
Nitrogen	30.4	37.8	17.7	37.8	24.4	18.5
Fluorine						
Phosphorus						
Sulfur						
Chlorine						
Arsenic						

Military obscuring smokes include titanium tetrachloride, FM smoke; FS smoke, a mixture of chlorosulfonic acid and sulfur trioxide; HC smoke, a mixture of aluminum, hexachloroethane, and zinc oxide; and white phosphorus (WP) smoke. The elemental make-up of these smokes is displayed in Table 3.

Table 3: Elemental composition in weight-% of military obscuring smokes.[12,13]

	FM	FS	HC	WP
Hydrogen		0.4		
Carbon			4.7	
Oxygen		51.5	9.2	
Aluminum			6.7	
Titanium	25.3			
Phosphorus				100.0
Sulfur		34.4		
Chlorine	74.7	13.7	41.9	
Zinc			37.5	

2.3 Fill identification decision tree

From the information in Tables 1 through 3, one may construct a simple decision tree to identify munition fills based on PGNAAs results. The decision tree used in PINS systems is shown in Figure 5. The decision-tree logic of Figure 5 is readily implemented as a computer program. The PINS system analyzes 8,192-channel gamma-ray spectra and executes the decision tree algorithm every ten seconds during data acquisition, presenting assay results in real time to the system operator.

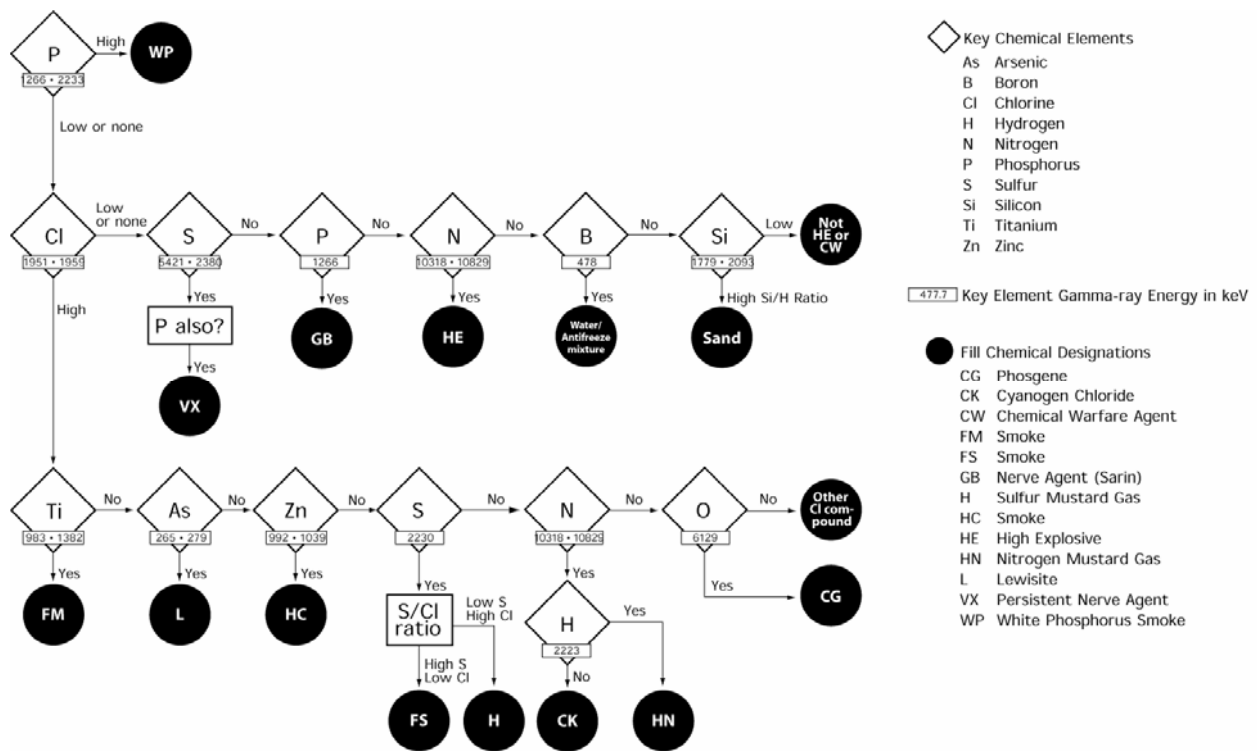

Figure 5: PINS decision tree logic

3. NEUTRON GENERATOR VS. Cf-252 EXCITATION FOR PGNA

Californium-252 is a relatively long-lived and reliable source of neutrons which is widely used in a number of industrial PGNA systems. It has a half-life of 2.645 years, allowing for an easy estimate of source intensity versus time, and decays via alpha emission (96.91% probability) and spontaneous fission (3.09% probability) with a specific neutron emission rate of $2.314 \times 10^6 \text{ n s}^{-1} \mu\text{g}^{-1}$. [14] For over 15 years ^{252}Cf has served as a reliable and effective neutron source for PINS PGNA chemical assay field work. [2,3] However, as explained above, there are some compelling reasons to consider using compact accelerator neutron generators in place of californium-252 including the higher neutron emission intensity and harder neutron spectrum of these devices as well as their ability to be turned-off when not in use. A brief comparison of some of the important differences between these two neutron sources is presented in Table 4 (for a descriptive example of compact accelerator neutron generator technology, see references 15 and 16).

Table 4: Comparison of Cf-252 and DT neutron generator parameters

Parameter	^{252}Cf (10 μg)	Neutron Generator
Neutron Yield, n/s	0.23×10^8	2×10^8
Neutron Spectrum	Watt Fission Spectrum	$14.1 \pm 0.1 \text{ MeV}$
Pulsing Range, Hz	Continuous only	Continuous up to 20,000
Power Consumption, W	0	50
Mass, kg	0.01	12
General Size, cm	$0.01 \times \text{Ø} 0.01$	$16 \times 60 \times 30$
2 mrem/hr stand-off distance, m	3.5	13.8

3.1. Advantages: logistics, safety, higher output, background issues

In terms of system performance, using higher energy neutrons from a DT source allows for the excitation of higher energy nuclear inelastic scattering reactions which are non-existent or very weak when interrogating using fission spectrum neutrons. Analysis using these inelastic reactions can help to improve precision and speed in the analytical determination of some CW agents and in identifying non-CW fill materials including high explosive identification based upon oxygen analysis. Beyond the important differences in acquired PGNA spectra between fission neutron and fusion neutron irradiated objects there are several practical advantages to using sealed-tube neutron generators in the field in comparison with using radioisotope sources. Most obvious is the ability to turn these sources off when they are not needed. By turning the neutron generator off, or into a stand-by mode where no neutrons are emitted, personnel can easily work around the generator to place test objects and equipment without being exposed to neutron radiation. Also, the off-state of these devices helps to reduce logistical complexities associated with the shipment of radionuclides since external radiation shielding, such as is used when shipping ^{252}Cf , is not needed. While special shipping and receiving processes must still be employed due to the tritium content of DT neutron generators, shipping these devices is significantly less complicated than for ^{252}Cf sources. As a reference it is worth noting that most compact accelerator neutron generators contain between 2 – 4 Ci of tritium; in comparison, industrial tritiated exit signs used in hotels and shopping centers, for example, can contain up to 20 Ci of tritium.

Other advantages when using neutron generators are their higher neutron yield (10x) in comparison to standard 10 μg ^{252}Cf sources, their pulsing ability and their lack of associated gamma-rays such as occur through spontaneous fission. Modern neutron generators are capable of up to several thousand hours of continuous, reliable operation. Gradual erosion of the metal hydride targets in these devices eventually leads to a decrease in neutron output to approximately 20% that of a new instrument under the same operating conditions. After this point is reached, however, they are then capable of further sustained output at this reduced yield level, which is still comparable to that of a new 10 μg ^{252}Cf source. The ability to pulse these devices allows for the possibility of separating data collection into two regimes, with the generator on and with the generator off, which under some circumstances can prove useful for improving the signal-to-noise ratio of PGNAA spectra. This can be a useful technique for dealing with interference reactions from the CW container. The lack of associated gamma-rays in fusion neutron generation can also be beneficial in reducing the intensity of collected PGNAA spectra under some circumstances.

3.2. Disadvantages: detector shielding problem, background issues

Some noteworthy disadvantages when using a neutron generator in comparison with ^{252}Cf are the instrument's size, complexity, and power requirements. Although today's neutron generators are much smaller and easier to use than comparable generators of ten years ago, they are still much larger and heavier than radioisotopes (although not that much larger or heavier than ^{252}Cf when its 20 kg radiation shielding/shipping container is also considered). In the standard PINS set-up a small polyethylene neutron reflector/moderator assembly is used to help boost the intensity of thermal neutrons in the test object measurement location. When using a neutron generator may be of equal or greater importance to use an external assembly to attempt to boost the thermal neutron intensity within the test object, depending upon the nature of the test object and its fill material. Unfortunately, the larger outer diameter of neutron generators in comparison with ^{252}Cf sources means that external moderator assemblies are larger and heavier than with the standard PINS set-up. While some tricks may be used in the design of these reflectors/moderators they are usually require several kilograms of material.[17] The complex nature of modern neutron generators often requires the use of a control computer. Fortunately, this is not usually a great disadvantage since a computer is normally present to control PGNAA data acquisition and analysis. Also, when used in remote locations, a battery-operated power supply may be required, further increasing PGNAA system size and weight.

Some additional disadvantages when using a neutron generator are the need for more extensive shadow shields in comparison with ^{252}Cf and the generation of spectral interferences in the PGNAA analysis from (n,n'), (n,2n), and (n,p) reactions in the vicinity of the measurement. For the standard PINS set-up with ^{252}Cf a layered shadow shield of roughly 10 cm of tungsten and 1 cm of Bi is used to protect the sensitive HPGe detector from fission neutrons and photons. Neutron attenuation in the shadow shield is especially important in order to avoid fast neutron damage in the germanium crystal. For a high yield DT neutron generator the dimensions of this shadow shield are significantly increased, requiring perhaps as much as 20-30 cm of tungsten and/or other high Z materials to ensure the fast neutron flux in the crystal is below neutron damage thresholds and below levels that introduce significant dead-time in the PGNAA

measurement. In addition to necessitating a thicker shadow shield, the high energy DT fusion neutrons also interact in nearby structural and background materials through more reaction channels than fission neutrons.[18] Additional gamma-ray photons from fast neutron interactions in the test object and other nearby materials, such as the detector stand, add more complexity to the PGNAA spectrum. Fortunately, with the use of a high resolution HPGe detector, these additional background photons can usually be distinguished from CW agent signatures in the PGNAA spectra.

3.3. Neutron generator reliability concerns

Radioisotope sources are the epitome of reliability, which is one reason why they are so often used in industrial applications requiring continuous analytical data acquisition. For PINS CW agent analysis, however, 24 hours-a-day, 365 days-a-year steady state operation is not needed. Typical PINS analysis for a suspect chemical artillery round, for example, is performed in 3,000 seconds or less, depending upon the nature of the test object and the type of fill. Up to ten or twelve munitions may be assayed over the course of a typical twelve-hour working day. In the past commercial neutron generators were typically capable of operating for only a few hundred hours (a period which often varied by a few hundred hours for identical products from the same vendor), after which catastrophic failure within the neutron tube of these devices resulted in an end state in which it was impossible to achieve further operation. Because of these relatively short lifetimes, and the inability to accurately predict when this catastrophic failure would occur, many users were often left with broken instruments and unplanned work stoppages as they waited for replacement of the neutron tube. During long test campaigns or in other time critical situations this unknown risk of system failure posed a significant drawback for introduction of neutron generators into industrial settings. In some cases users would preventively change-out the neutron tube every 100-200 hours in order to avoid encountering catastrophic failure in the field. Either waiting for instrument repair or using preventative change-out, the solution was expensive and unacceptable for field operations expected to go for more than a few weeks of daily use between field service intervals.

Over the past 10 years; however, significant advances have been made in the design of sealed neutron tubes used within neutron generators, reaching a point where catastrophic failure is rare and the primary “failure” mechanism is a slow degradation in neutron output over time which. In some cases the generator’s neutron output level drops to a level at which the neutron tube must be replaced in order to meet particular goals for data acquisition time or sensitivity but in some cases the original generator neutron output exceeds the applications requirements with sufficient margin such that even degraded output is acceptable. Another aspect of system reliability for industrial applications is start-up time. For modern neutron generators typical transition times from a stand-by state to full output operation are 30-45 seconds, compared with waiting periods of up to 10 minutes in older systems. Even with significant target erosion and loss of neutron yield it is likely that a neutron generator used in a PINS system should be able to be used reliably for several years before neutron tube replacement is needed.

Beyond the reliability of modern neutron generators in terms of neutron output, there are valid concerns regarding the ruggedness of these devices and their suitability for field use. Despite careful design considerations such as the qualification of Thermo Electron’s MP320 neutron

generator as a certified pressure vessel (to allow shipment with pressurized sulfur hexafluoride (SF₆) insulating gas in the neutron generator), modern commercial neutron generators are sensitive electronic instruments and must be handled carefully. Their design is far from being capable of meeting typical MILSPEC performance specification for shock and vibration, for example, and their associated control electronics enclosures do not typically meet higher level environmental protection criteria such as the NEMA 4 standard. Despite these limitations it is still probable that modern commercial neutron generators will prove satisfactorily rugged for typical PINS field work. As a reference it is worth noting that HPGe detectors used in PINS systems, which are probably more sensitive to environmental insults than neutron generators, are routinely and successfully used by field technicians and military personnel around the world under extreme conditions of temperature, humidity, and blowing sand.

References

- [1] Prentiss, A. M., *Chemistry in War*, (New York, NY: McGraw-Hill Co., 1937) p. 460.
- [2] Caffrey, A. J., Cole, J. D., Gehrke, R. J., and Greenwood, R. C., "Elemental Assay of Chemical Warfare Agents and High Explosive Munitions by Spectroscopy of Neutron-Induced Gamma Rays: Tests at Tooele Army Depot, 22 April 91 – 2 May 91", Idaho National Engineering Laboratory Report EGG-PHY-9816 (1991).
- [3] Caffrey, A.J., Cole, J.D., Gehrke, R.J., and Greenwood, R.C., "Chemical Warfare Agent and High Explosive Identification by Spectroscopy of Neutron-Induced Gamma Rays," *IEEE Transactions on Nuclear Science* **39** (1992) 1422-1426.
- [4] The United States is in the process of destroying its entire stockpile of chemical warfare agents, in accordance with the 1993 Chemical Weapons Convention.
- [5] The commercial version of the PINS instrument is described at www.ortec-online.com/pdf/pins.pdf.
- [6] Alvarez, R.A., Dougan, A.D., Rowland, M.R., and Wang, T.F., "Neutron Interrogation to Identify Chemical Elements with an Ion-Tube Neutron Source (INS)," *Journal of Radioanalytical and Nuclear Chemistry* **192** (1995) 73-80.
- [7] The Brüker NIGAS PGNA system is described at www.bdal.com.
- [8] Steward, S. and Forsht, D., "Use of nuclear techniques to describe the fill of found unexploded ordnance," *Applied Radiation and Isotopes* **63** (2005) 795-797.
- [9] See for example, Firestone, R.B. and Shirley, V.S., eds., *Table of Isotopes*, 8th Edition (New York: Wiley-Interscience, 1998). This two-volume compilation of atomic nuclei energy levels and their associated gamma-ray energies and intensities runs to over 3,000 pages.
- [10] Budavari, S. ed., *The Merck Index, 11th Edition* (Rahway, N.J: Merck & Co., Inc., 1989).
- [11] Meyer, R. *Explosives, Third Edition* (New York, NY: VCH Publishers, 1987).
- [12] *Military Chemistry and Chemical Compounds*, U.S. Army Field Manual FM 3-9 (1975).
- [13] Prentiss, A. M., *Chemistry in War*, (New York, NY: McGraw-Hill Co., 1937).
- [14] Martin, R. C., Knauer, J. B., and Balo, P. A., "Production, Distribution and Applications of Californium-252 Neutron Sources," *Applied Radiation and Isotopes* **53** (2000) 785-792.
- [15] Chichester, D. L. and Simpson, J. D., "Compact Accelerator neutron Generators," *The Industrial Physicist*, Dec./Jan. (2003/2004) 22.
- [16] Chichester, D. L., Simpson, J. D., and Lemchak, M., J., "Advanced Compact Accelerator Neutron Generator Technology for Active Neutron Interrogation Field Work," *Journal of Radioanalytical and Nuclear Chemistry* **271** (2007) 629-637.
- [17] Chichester, D. L., "Use Of An Internal Moderator Within A Portable Sealed Tube Neutron Generator," *Transactions of the American Nuclear Society* **87** (2002) 430-431.
- [18] Demidov, A. M., Govor, L. I., Cherepantsev, Yu. K., Ahmed, M. R., Al-Najjar, S., Al-Amili, M. A., Al-Assafi, N., and Rammo, N., *Atlas of Gamma-Ray Spectra from Inelastic Scattering of Reactor Fast Neutrons* (Moscow, USSR: Atomizdat, 1978).