

## The Complete, Economical, and Easy to Install Multichannel Analyzer System

- **926 MCB in a one-wide NIM**
  - 8000-channel ADC (8  $\mu$ s)
  - Two methods for Dead-Time correction
  - 2 billion counts/channel
  - Multiple presets
  - Multiple computer interfaces
  - GATE, BUSY, and PUR Inputs
- **USB connectivity**
  - Simple to install USB Interface
  - Direct connection to legacy ORTEC devices
  - Optional interface for PC parallel port connection
- **MAESTRO-32 MCA emulation software**
  - Advanced peak search algorithms
  - Windows graphical user interface



The ORTEC Model 926 Multichannel Buffer (MCB) is a single-wide NIM module designed for high performance in real-time data acquisition. The 926 is a hardware component that provides Analog-to-Digital Conversion (ADC) and Memory. A personal computer is interfaced, through the provided USB connector, to utilize the data acquisition, storage, display, and analysis functions. This is accomplished by issuing ASCII commands from the PC to the 926 MCB's internal 80C188 microprocessor.

Extended Live-Time correction according to the Gedcke-Hale method,<sup>1</sup> or Simple Live-Time correction with the clock turned off during the conversion time, can be selected using printed wiring board jumpers.

MAESTRO-32 MCA Emulation software and quantitative analysis software are available for use with a variety of personal computers in the Windows environment. The easy-to-use command language complies with the standard NIM digital bus NIM/488 per DOE/ER-0457T (formerly NIM/GPIB) protocol definitions.<sup>2</sup> Control of all functions, including acquisition, presets, and ADC conversion gain are provided using this protocol.

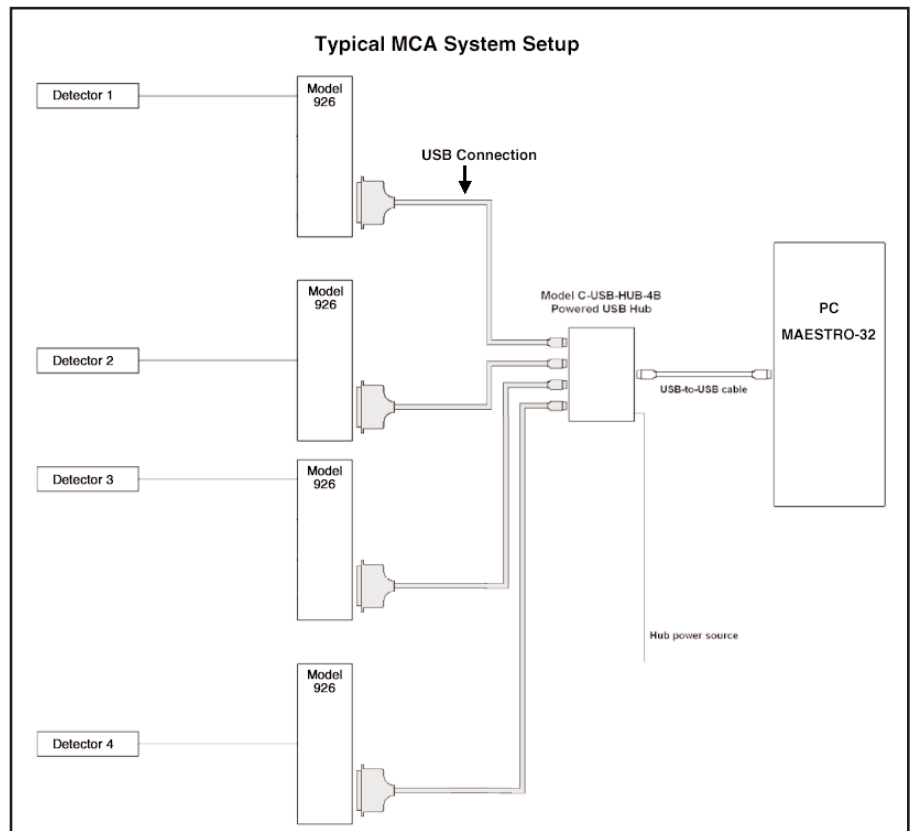

## USB Connectivity

The USB connector allows you to operate the 926 MCB from any supported computer that has an available USB port. The cable provided has a 37-pin D-connector that is attached to the rear of the 926 MCB. The USB connector is then plugged into the PC USB port. You can even connect multiple 926 MCBs into a single PC, through a powered USB hub.

If you have an older PC that does not have USB ports, an optional female 25-pin D-connector is provided. To utilize, simply remove the manufacturer installed connector and mount the optional female connector. Attach the 926 MCB to your PC using the optional Interface/Cable Pack.



## The 926 Operates with the Latest MCA Emulation Software . . .

MAESTRO-32 MCA Emulation provides, under the popular Windows Graphical User interface, an advanced MCA Emulator that is easy to use by keyboard or mouse. The truly live spectral display is easily manipulated with the mouse; rapid peak searches, ROI settings, and nuclide activity calculations are just a button click away. "Hot" keys are included for many functions. Up to 16k-channel full display, with logarithmic and variable-linear vertical display scale, is available. Advanced features include:

- Mariscotti<sup>2</sup> fast peak search and nuclide ID
- Index to next ROI or peak in spectrum
- Automatic operation through command file feature
- Live update of key peak parameters while data is collecting
- Peak centroid and shape calculation
- Net Area and Gross Area for peaks
- Spectrum Sum
- Spectrum Smooth
- Quadratic energy calibration, with shape parameter, stored to disk

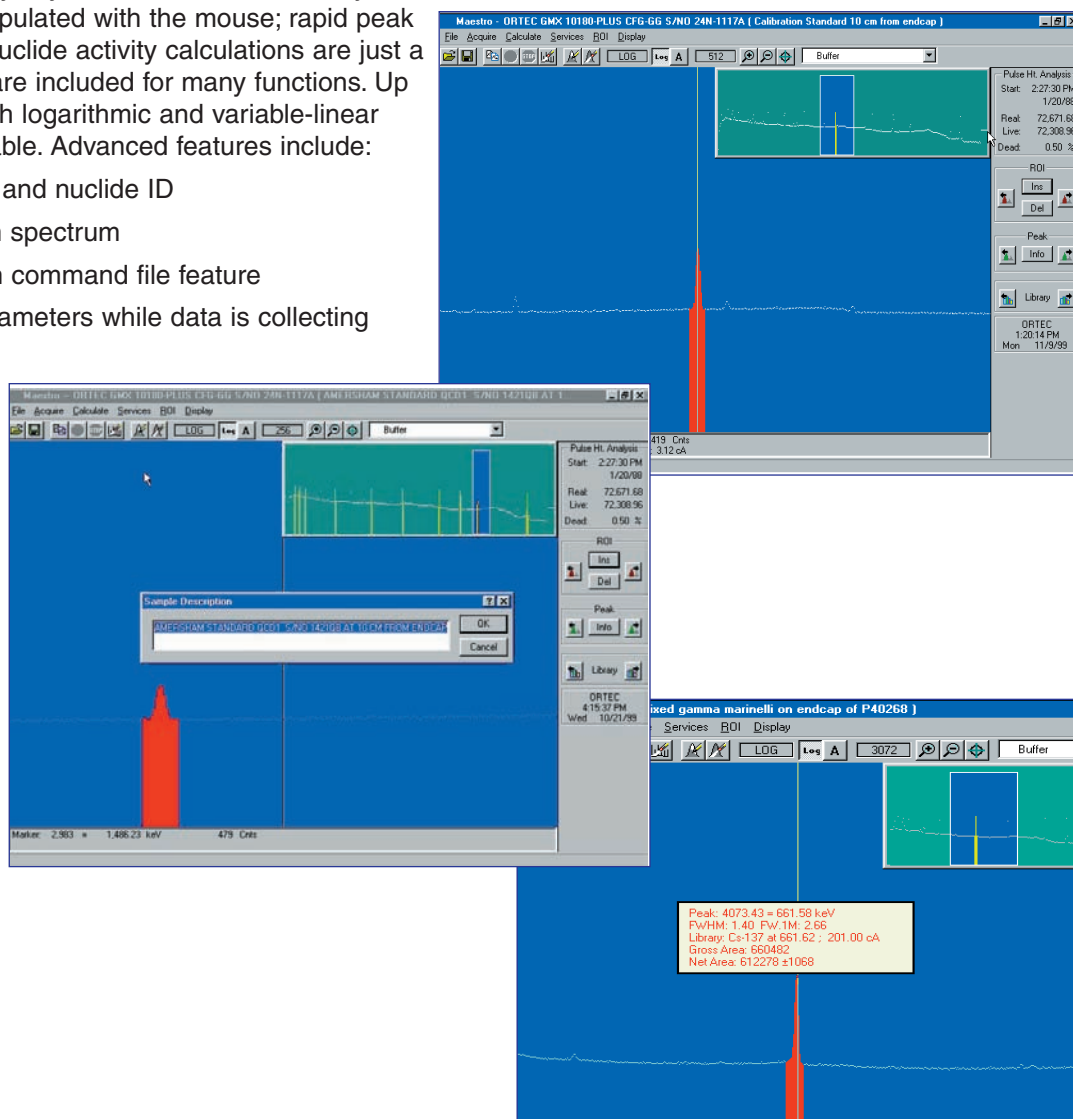

# 926-M32-USB

## Multichannel Analyzer

### Specifications

#### PERFORMANCE

**ADC** Successive-approximation type with sliding-scale linearization.

**MAX RESOLUTION** 8192 channels, software selectable as 8192, 4096, 2048, 1024, and 512.

**DEAD TIME PER EVENT** 8  $\mu$ s, including memory transfer.

**INTEGRAL NONLINEARITY**  $\pm 0.025\%$  over the top 99% of the dynamic range.

**DIFFERENTIAL NONLINEARITY**  $< \pm 1\%$  over the top 99% of the dynamic range.

**GAIN INSTABILITY**  $\leq \pm 50$  ppm/ $^{\circ}$ C.

**DEAD TIME CORRECTION** Printed wiring board jumper selects either Extended Live Time correction according to the Gedcke-Hale method, or Simple Live Time correction with the clock turned off during the conversion time.

**DATA MEMORY** 8k channels of battery backed-up memory;  $2^{31}-1$  counts per channel (over 2 billion).

#### PRESETS

**Real Time/Live Time** Multiples of 20 ms.

**Region of Interest** Peak count/Integral count.

**Data Overflow** Terminates acquisition when any channel exceeds  $2^{31}-1$ .

**MICROPROCESSOR** Intel 80C188; 32k Dual-Port RAM with battery backup; 16k "scratchpad" RAM with battery backup. 32k program memory.

#### FRONT-PANEL INDICATORS AND CONTROLS

**CPU BUSY** Red, busy-rate LED; intensity indicates the relative activity of the microprocessor.

**ADC BUSY** Red, busy-rate LED flashes once for each pulse digitized by ADC.

**ADC ZERO** Screwdriver potentiometer,  $\pm 250$  mV.

**ADC LLD** Screwdriver potentiometer, from 0 to 10% full scale.

#### INPUTS AND OUTPUTS

**INPUT** Accepts positive unipolar, positive gated-integrator, or positive-leading bipolar analog pulses in the dynamic range from 0 to +10 V; +12 V maximum; semi-Gaussian-shaped or gated-integrator-shaped time constants from 0.25 to 30  $\mu$ s, or delay-line-shaped with width  $> 0.25$   $\mu$ s.  $Z_{in} \approx 1$  k $\Omega$ , dc-coupled. No internal delay. BNC connectors on front and rear panel.

**ADC GATE** Optional, slow-positive NIM input. Computer-selectable Coincidence or Anticoincidence. Signal must occur prior to and extend 0.5  $\mu$ s beyond the peak of the pulse; front-panel BNC connector.  $Z_{in} \sim 1$  k $\Omega$ .

**PUR** Pile-up rejection input; accepts slow-positive NIM signal; signal must occur prior to peak detect.  $Z_{in} > 1$  k $\Omega$ . BNC connector on rear panel.

**BUSY** Busy input used by live-time correction circuits. Accepts slow-positive NIM signal; signal must occur prior to peak detect.  $Z_{in} > 1$  k $\Omega$ . BNC connector on rear panel.

**DUAL-PORT MEMORY (ORTEC)** 37-pin D-connector provides the PC with a communication link and direct access to the Model 926's internal data memory.

**PARALLEL PORT** Provides for control of the instrument and access to the data memory from a standard IBM PC printer port; male 25-pin D-connector.

**PRINTER** User installed connection provided to attach either another 926 MCB or a printer to the system; jumper selectable; female 25-pin D-connector.

#### ELECTRICAL AND MECHANICAL

**POWER REQUIRED** +12 V, 200 mA; -12 V, 200 mA; +6 V, 600 mA.

#### WEIGHT

Net 0.9 kg (2 lb).

Shipping 2.25 kg (5 lb).

**DIMENSIONS** NIM-standard single-wide 3.43 x 22.13 cm (1.35 x 8.714 in.) front panel per DOE/ER0457T.



# 926-M32-USB

## Multichannel Analyzer

### Ordering Information

To order, specify:

Model	Description
926-M32-USB	926 Multichannel Buffer MAESTRO-32 for Windows MCA Emulation Software Driver update (CONNECTIONS-32) DPM to USB interface converter (5 meters) Female 25-pin D-connector
926-USB	926 Multichannel Buffer DPM to USB interface converter (5 meters) Female 25-pin D-connector
926-M32	926 Multichannel Buffer MAESTRO-32 for Windows MCA Emulation Software Female 25-pin D-connector
926	926 Multichannel Buffer Female 25-pin D-connector

### Interface/Cable Packs

#### Printer Port Operation

926-C-10	Cable, RS-232-C, 25 conductor, 10 feet (3 m), male to female
926-C-2	Cable, RS-232-C, 25 conductor, 2 feet (0.6 m), male to female

#### Optional Integrated Software

A66-B32	GammaVision Gamma-Ray Analysis with Ge
Global Value	Gamma Spectroscopy Automation and Custom Reporting

#### Additional hardware options:

USB HUB: Powered USB hub includes connections for up to seven 926 inputs. Configuration functions are the same as any other Connections-32 device. Available in 4-input and 7-input models.

C-USB-HUB-4B	4 Port USB Hub
C-USB-HUB-7B	7 Port USB Hub
USBEXT	USB Active Extension Cable (powered by USB)

<sup>1</sup>Ron Jenkins, R.W. Gould, and Dale Gedcke, Quantitative X-Ray Spectrometry (New York: Marcel Dekker, Inc.), 1981, pp. 266–267.

<sup>2</sup>Please refer to "Standard NIM Digital Bus (NIM/488)," DOE/ER-0457T, U.S. NIM committee, May 1990; Standard NIM Instrumentation System, NTIS, U.S. Dept. of Commerce, Springfield, Virginia 22161.

Specifications subject to change  
061407

**ORTEC**<sup>®</sup>

[www.ortec-online.com](http://www.ortec-online.com)

Tel. (865) 482-4411 • Fax (865) 483-0396 • [ortec.info@ametek.com](mailto:ortec.info@ametek.com)  
801 South Illinois Ave., Oak Ridge, TN 37831-0895 U.S.A.  
For International Office Locations, Visit Our Website

**AMETEK**<sup>®</sup>  
ADVANCED MEASUREMENT  
TECHNOLOGY