

- Compact size (~37-in. long and 12-in. diameter)
- Weight ~100 lbs
- Totally waterproof, submersible
- LN₂ refillable without opening the shroud cover
- Split-ring lead shield for shielding and negative buoyancy
- HPGe coaxial detector
- Preamp, H.V. filter, LN₂ level probe, and H.V. cutoff protection included
- 30-foot operating depth
- Stainless steel shroud for easy cleaning and decontamination
- Thin (30 mil) side window in shroud to enable low energy photon (≥ 50 keV) spectroscopy

The ORTEC Submersible Photon Detector (SPD-1) is designed for nuclear fuel element scanning in storage pools. The SPD-1 is useful in other similar applications that require a totally waterproof, submersible photon detector for shallow depth pools. In the fuel element scanning application, high-resolution spectroscopy is desired, dictating the use of a High-Purity Germanium (HPGe) Photon Detector. As with all germanium detectors, liquid nitrogen (LN₂) cooling is required for operation. A special compact LN₂ dewar (thermos vessel) supplies 20 liters of LN₂ during operation. The dewar can be refilled at the surface of the pool without removing the waterproof shroud cover. Operating time of the SPD-1, before LN₂ refilling is required, is approximately 12 to 14 days. An LN₂ low level alarm and high-voltage (H.V.) cutoff circuitry monitor and protect the system.

The compact (approximately 37-in long x 12-in. diameter) stainless steel shroud contains the HPGe detector element, cryogenic package, 20-liter LN₂ dewar, LN₂ level probe, preamplifier, H.V. filter, and lead shield. The split-ring lead shield is provided behind the detector element to shield from contaminated water in the pool and also to provide negative buoyancy to the system. The stainless steel package has three lifting eyes and can be easily cleaned or decontaminated. The particular system shown was designed for pool depths up to 30 feet. Polyvinyl chloride tubing is used to carry the electrical cables to and from the detector package and to vent the LN₂ to the pool surface. A thin (30 mil) side window is provided in the stainless steel shroud to enable low energy photons (down to 50 keV) to enter the detector package.



The particular system shown was designed for pool depths up to 30 feet. Polyvinyl chloride tubing is used to carry the electrical cables to and from the detector package and to vent the LN₂ to the pool surface. A thin (30 mil) side window is provided in the stainless steel shroud to enable low energy photons (down to 50 keV) to enter the detector package.

SPD-1 Submergible Photon Detector

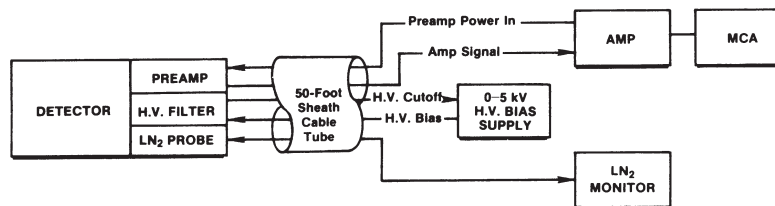
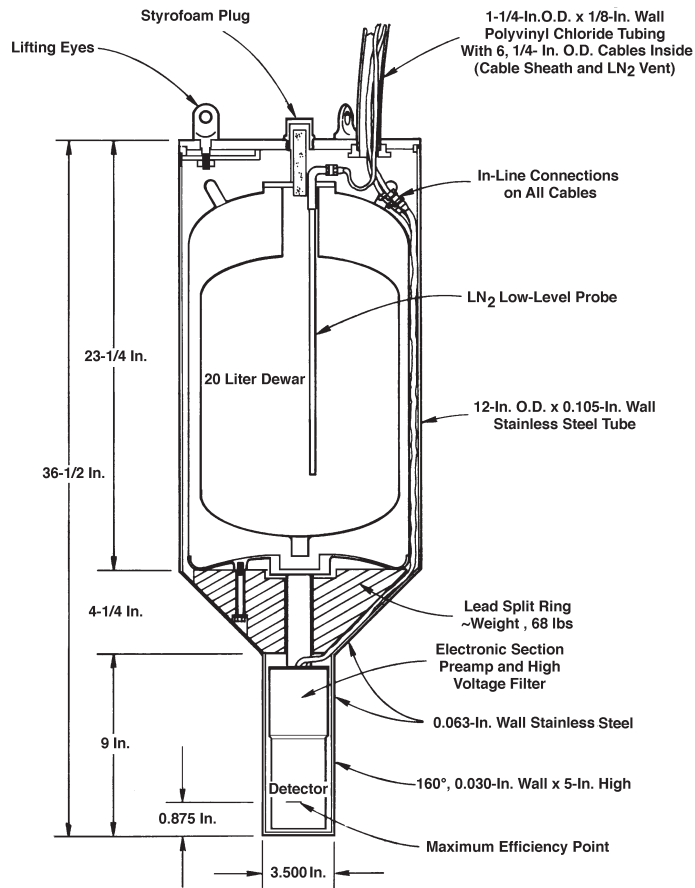

Detailed Illustration of the ORTEC Submergible Photon Detector (SPD-1)

Specifications subject to change
110207

ORTEC[®]

www.ortec-online.com

Tel. (865) 482-4411 • Fax (865) 483-0396 • ortec.info@ametek.com
801 South Illinois Ave., Oak Ridge, TN 37831-0895 U.S.A.
For International Office Locations, Visit Our Website

AMETEK[®]
ADVANCED MEASUREMENT
TECHNOLOGY